

PURPOSE AND PROCEDURE

The tables and histograms which follow are to be used only within the analytical framework detailed in the main body of this guideline.

Histograms precede any table with 10 or more entries. The use and interpretation of these histograms is explained in Part 2 of the guideline. The tables are in a format similar to that found in the model building codes. The following example, taken from an entry in Table 1.1.2, best explains the table format.

1. Item Code: The item code consists of a four place series in the general form w-x-y-z in which each member of the series denotes the following:

- w = Type of building element (e.g., W=Walls; F=Floors, etc.)
- x = The building element thickness rounded down to the nearest one inch increment (e.g., 4⁵/₈ inches is rounded off to 4 inches)
- y = The general type of material from which the building element is constructed (e.g., M=Masonry; W=Wood, etc.)
- z = The item number of the particular building element in a given table

The item code shown in the example W-4-M-50 denotes the following:

- W = Wall, as the building element
- 4 = Wall thickness in the range of 4 inches (102 mm) to less than 5 inches (127 mm)
- M = Masonry construction
- 50 = The 50th entry in Table 1.1.2

- 2. The specific name or heading of this column identifies the dimensions which, if varied, has the greatest impact on fire resistance. The critical dimension for walls, the example here, is thickness. It is different for other building elements (e.g., depth for beams; membrane thickness for some floor/ceiling assemblies). The table entry is the named dimension of the building element measured at the time of actual testing to within ± 1/8 inch (3.2 mm) tolerance. The thickness tabulated includes facings where facings are a part of the wall construction.
- 3. Construction Details: The construction details provide a brief description of the manner in which the building element was constructed.

4. Performance: This heading is subdivided into two columns. The column labeled “Load” will either list the load that the building element was subjected to during the fire test or it will contain a note number which will list the load and any other significant details. If the building element was not subjected to a load during the test, this column will contain “n/a,” which means “not applicable.”

The second column under performance is labeled “Time” and denotes the actual fire endurance time observed in the fire test.

- 5. Reference Number: This heading is subdivided into three columns: Pre-BMS-92; BMS-92; and Post-BMS-92. The table entry under this column is the number in the Bibliography of the original source reference for the test data.
- 6. Notes: Notes are provided at the end of each table to allow a more detailed explanation of certain aspects of the test. In certain tables the notes given to this column have also been listed under the “Construction Details” and/or “Load” columns.
- 7. Rec Hours: This column lists the recommended fire endurance rating, in hours, of a building element. In some cases, the recommended fire endurance will be less than that listed under the “Time” column. In no case is the “Rec Hours” greater than given in the “Time” column.

ITEM CODE	THICKNESS	CONSTRUCTION DETAILS	PERFORMANCE		REFERENCE NUMBER			NOTES	REC. HOURS
			LOAD	TIME	PRE-BMS-92	BMS-92	POST-BMS-92		
W-4-M-50	4 ⁵ / ₈ ”	Core: structural clay tile, See notes 12, 16, 21; Facings on unexposed side only, see note 18	n/a	25 min.		1		3, 4, 24	1/3

SECTION I - WALLS
FIGURE 1.1.1—WALLS—MASONRY
0" TO LESS THAN 4" THICK

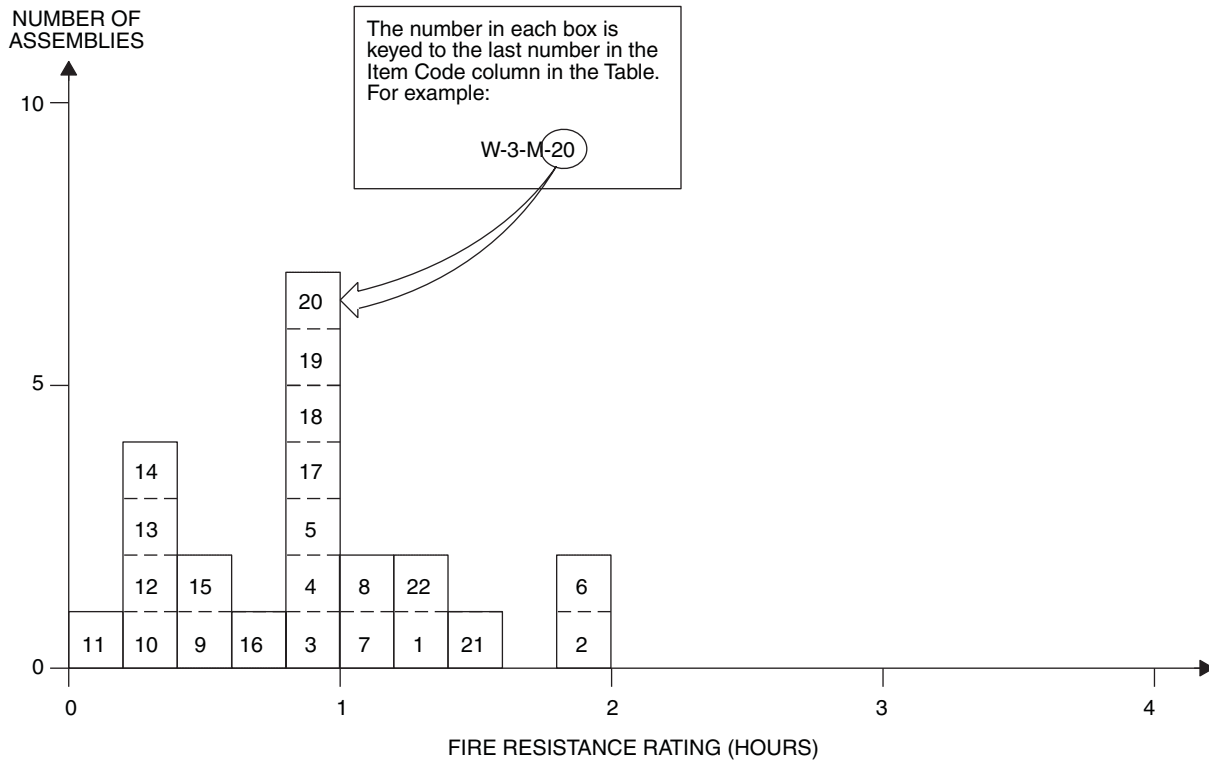

TABLE 1.1.1—MASONRY WALLS
0" TO LESS THAN 4" THICK

ITEM CODE	THICKNESS	CONSTRUCTION DETAILS	PERFORMANCE		REFERENCE NUMBER			NOTES	REC. HOURS
			LOAD	TIME	PRE-BMS-92	BMS-92	POST-BMS-92		
W-2-M-1	2 1/4"	Solid partition; 3/4" gypsum plank- 10' x 1'6"; 3/4" plus gypsum plaster each side.	N/A	1 hr. 22 min.			7	1	1 1/4
W-3-M-2	3"	Concrete block (18" x 9" x 3") of fuel ash, portland cement and plasticizer; cement/sand mortar.	N/A	2 hrs.			7	2, 3	2
W-2-M-3	2"	Solid gypsum block wall; No facings	N/A	1 hr.		1		4	1
W-3-M-4	3"	Solid gypsum blocks, laid in 1:3 sanded gypsum mortar.	N/A	1 hr.		1		4	1
W-3-M-5	3"	Magnesium oxysulfate wood fiber blocks; 2" thick, laid in portland cement-lime mortar; Facings: 1/2" of 1:3 sanded gypsum plaster on both sides.	N/A	1 hr.		1		4	1
W-3-M-6	3"	Magnesium oxysulfate bound wood fiber blocks; 3" thick; laid in portland cement-lime mortar; Facings: 1/2" of 1:3 sanded gypsum plaster on both sides.	N/A	2 hrs.		1		4	2

(Continued)

**TABLE 1.1.1—MASONRY WALLS
0" TO LESS THAN 4" THICK—continued**

ITEM CODE	THICKNESS	CONSTRUCTION DETAILS	PERFORMANCE		REFERENCE NUMBER			NOTES	REC. HOURS
			LOAD	TIME	PRE-BMS-92	BMS-92	POST-BMS-92		
W-3-M-7	3"	Clay tile; Ohio fire clay; single cell thick; Face plaster: 5/8" (both sides) 1:3 sanded gypsum; Design "E," Construction "A."	N/A	1 hr. 6 min.	0.		2	5, 6, 7, 11, 12, 39	1
W-3-M-8	3"	Clay tile; Illinois surface clay; single cell thick; Face plaster: 5/8" (both sides) 1:3 sanded gypsum; Design "A," Construction "E."	N/A	1 hr. 1 min			2	5, 8, 9, 11, 12, 39	1
W-3-M-9	3"	Clay tile; Illinois surface clay; single cell thick; No face plaster; Design "A," Construction "C."	N/A	25 min.			2	5, 10, 11, 12, 39	1/3
W-3-M-10	3 7/8"	8" x 4 7/8" glass blocks; weight 4 lbs. each; portland cement-lime mortar; horizontal mortar joints reinforced with metal lath.	N/A	15 min.		1		4	1/4
W-3-M-11	3"	Core: structural clay tile; see Notes 14, 18, 13; No facings.	N/A	10 min.		1		5, 11, 26	1/6
W-3-M-12	3"	Core: structural clay tile; see Notes 14, 19, 23; No facings.	N/A	20 min.		1		5, 11, 26	1/3
W-3-M-13	3 5/8"	Core: structural clay tile; see Notes 14, 18, 23; Facings: unexposed side; see Note 20.	N/A	20 min.		1		5, 11, 26	1/3
W-3-M-14	3 5/8"	Core: structural clay tile; see Notes 14, 19, 23; Facings: unexposed side only; see Note 20.	N/A	20 min.		1		5, 11, 26	1/3
W-3-M-15	3 5/8"	Core: clay structural tile; see Notes 14, 18, 23; Facings: side exposed to fire; see Note 20.	N/A	30 min.		1		5, 11, 26	1/2
W-3-M-16	3 5/8"	Core: clay structural tile; see Notes 14, 19, 23; Facings: side exposed to fire; see Note 20.	N/A	45 min.		1		5, 11, 26	3/4
W-2-M-17	2"	2" thick solid gypsum blocks; see Note 27.	N/A	1 hr.		1		27	1
W-3-M-18	3"	Core: 3" thick gypsum blocks 70% solid; see Note 2; No facings.	N/A	1 hr.		1		27	1
W-3-M-19	3"	Core: hollow concrete units; see Notes 29, 35, 36, 38; No facings.	N/A	1 hr.		1		27	1
W-3-M-20	3"	Core: hollow concrete units; see Notes 28, 35, 36, 37, 38; No facings.	N/A	1 hr.		1			1
W-3-M-21	3 1/2"	Core: hollow concrete units; see Notes 28, 35, 36, 37, 38; Facings: one side; see Note 37.	N/A	1 1/2 hrs.		1			1 1/2

(Continued)

RESOURCE A

**TABLE 1.1.1—MASONRY WALLS
0" TO LESS THAN 4" THICK—continued**

ITEM CODE	THICKNESS	CONSTRUCTION DETAILS	PERFORMANCE		REFERENCE NUMBER			NOTES	REC. HOURS
			LOAD	TIME	PRE-BMS-92	BMS-92	POST-BMS-92		
W-3-M-22	3 1/2"	Core: hollow concrete units; see Notes 29, 35, 36, 38; Facings: one side, see Note 37.	N/A	1 1/4 hrs.		1			1 1/4

For SI: 1 inch = 25.4 mm, 1 pound per square inch = 0.00689 MPa, °C = [(°F) - 32]/1.8.

Notes:

1. Failure mode - flame thru.
2. Passed 2-hour fire test (Grade "C" fire res. - British).
3. Passed hose stream test.
4. Tested at NBS under ASA Spec. No. A2-1934. As nonload bearing partitions.
5. Tested at NBS under ASA Spec. No. 42-1934 (ASTM C 19-33) except that hose stream testing where carried was run on test specimens exposed for full test duration, not for a reduced period as is contemporarily done.
6. Failure by thermal criteria - maximum temperature rise 325°F.
7. Hose stream failure.
8. Hose stream - pass.
9. Specimen removed prior to any failure occurring.
10. Failure mode - collapse.
11. For clay tile walls, unless the source or density of the clay can be positively identified or determined, it is suggested that the lowest hourly rating for the fire endurance of a clay tile partition of that thickness be followed. Identified sources of clay showing longer fire endurance can lead to longer time recommendations.
12. See appendix for construction and design details for clay tile walls.
13. Load: 80 psi for gross wall area.
14. One cell in wall thickness.
15. Two cells in wall thickness.
16. Double shells plus one cell in wall thickness.
17. One cell in wall thickness, cells filled with broken tile, crushed stone, slag cinders or sand mixed with mortar.
18. Dense hard-burned clay or shale tile.
19. Medium-burned clay tile.
20. Not less than 3/8 inch thickness of 1:3 sanded gypsum plaster.
21. Units of not less than 30 percent solid material.
22. Units of not less than 40 percent solid material.
23. Units of not less than 50 percent solid material.
24. Units of not less than 45 percent solid material.
25. Units of not less than 60 percent solid material.
26. All tiles laid in portland cement-lime mortar.
27. Blocks laid in 1:3 sanded gypsum mortar voids in blocks not to exceed 30 percent.
28. Units of expanded slag or pumice aggregate.
29. Units of crushed limestone, blast furnace, slag, cinders and expanded clay or shale.
30. Units of calcareous sand and gravel. Coarse aggregate, 60 percent or more calcite and dolomite.
31. Units of siliceous sand and gravel. Ninety percent or more quartz, chert or flint.
32. Unit at least 49 percent solid.
33. Unit at least 62 percent solid.
34. Unit at least 65 percent solid.
35. Unit at least 73 percent solid.
36. Ratings based on one unit and one cell in wall thickness.
37. Minimum of 1/2 inch - 1:3 sanded gypsum plaster.
38. Nonload bearing.
39. See Clay Tile Partition Design Construction drawings, below.

(Continued)

**TABLE 1.1.1—MASONRY WALLS
0" TO LESS THAN 4" THICK—continued**

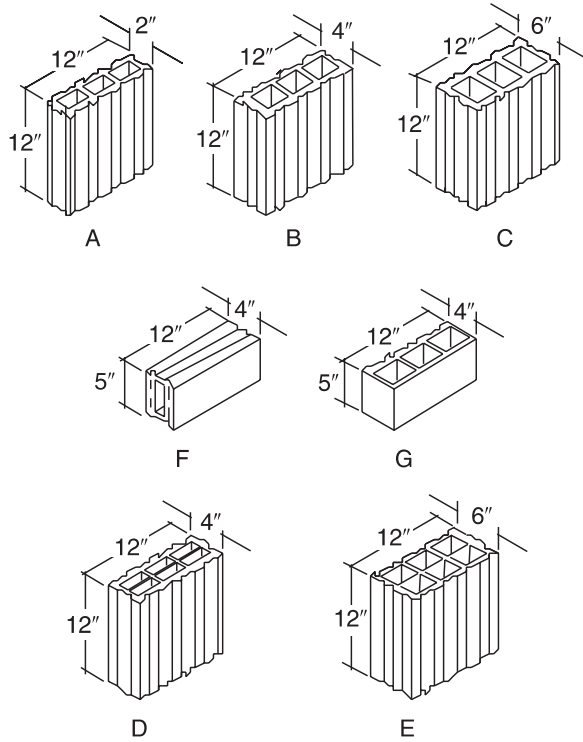

DESIGNS OF TILES USED IN FIRE-TEST PARTITIONS

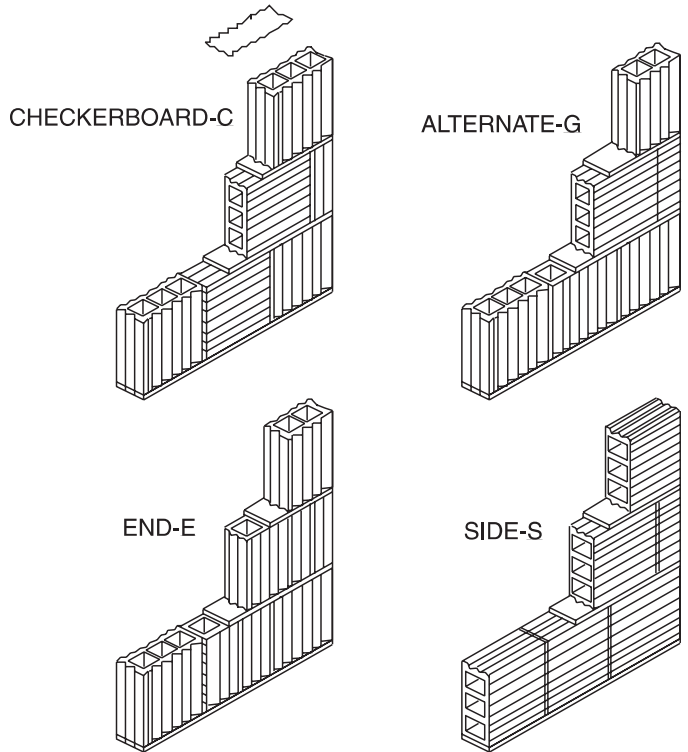

THE FOUR TYPES OF CONSTRUCTION USED
IN FIRE-TEST PARTITIONS

**FIGURE 1.1.2—MASONRY WALLS
4" TO LESS THAN 6" THICK**

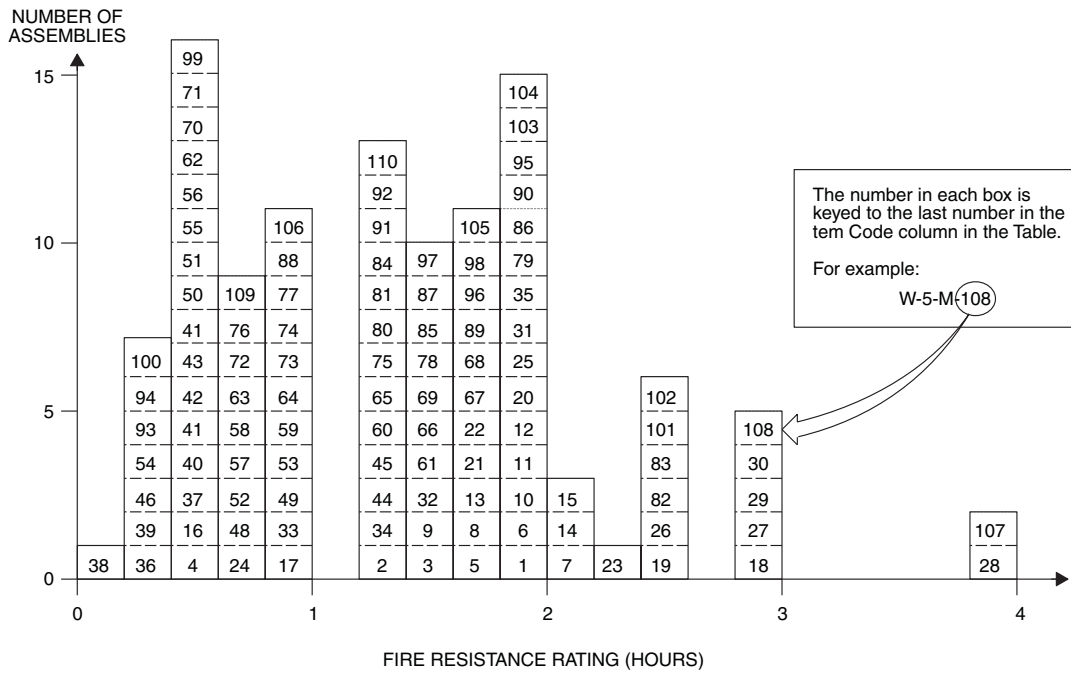

**TABLE 1.1.2—MASONRY WALLS
4" TO LESS THAN 6" THICK**

ITEM CODE	THICKNESS	CONSTRUCTION DETAILS	PERFORMANCE		REFERENCE NUMBER			NOTES	REC. HOURS
			LOAD	TIME	PRE-BMS-92	BMS-92	POST-BMS-92		
W-4-M-1	4"	Solid 3" thick, gypsum blocks laid in 1:3 sanded gypsum mortar; Facings: 1/2" of 1:3 sanded gypsum plaster (both sides).	N/A	2 hrs.		1		1	2
W-4-M-2	4"	Solid clay or shale brick.	N/A	1 hr. 15 min.		1		1, 2	1 1/4
W-4-M-3	4"	Concrete; No facings.	N/A	1 hr. 30 min.		1		1	1 1/2
W-4-M-4	4"	Clay tile; Illinois surface clay; single cell thick; No face plaster; Design "B," Construction "C."	N/A	25 min.			2	3-7, 36	1/3
W-4-M-5	4"	Solid sand-lime brick.	N/A	1 hr. 45 min.		1		1	1 3/4
W-4-M-6	4"	Solid wall; 3" thick block; 1/2" plaster each side; 17 3/4" x 8 3/4" x 4" "Breeze Blocks"; portland cement/sand mortar.	N/A	1 hr. 52 min.			7	2	1 3/4
W-4-M-7	4"	Concrete (4020 psi); Reinforcement: vertical 3/8"; horizontal 1/4"; 6" x 6" grid.	N/A	2 hrs. 10 min.			7	2	2
W-4-M-8	4"	Concrete wall (4340 psi crush); reinforcement 1/4" diameter rebar on 8" centers (vertical and horizontal).	N/A	1 hr. 40 min.			7	2	1 2/3

(Continued)

**TABLE 1.1.2—MASONRY WALLS
4" TO LESS THAN 6" THICK—continued**

ITEM CODE	THICKNESS	CONSTRUCTION DETAILS	PERFORMANCE		REFERENCE NUMBER			NOTES	REC. HOURS
			LOAD	TIME	PRE-BMS-92	BMS-92	POST-BMS-92		
W-4-M-9	4 ³ / ₁₆ "	4 ³ / ₁₆ " × 2 ⁵ / ₈ " cellular fletton brick (1873 psi) with 1/2" sand mortar; bricks are U-shaped yielding hollow cover (approx. 2" × 4") in final cross-section configuration.	N/A	1 hr. 25 min.			7	2	1 ¹ / ₃
W-4-M-10	4 ¹ / ₄ "	4 ¹ / ₄ " × 2 ¹ / ₂ " fletton (1831 psi) brick in 1/2" sand mortar.	N/A	1 hr. 53 min			7	2	1 ³ / ₄
W-4-M-11	4 ¹ / ₄ "	4 ¹ / ₄ " × 2 ¹ / ₂ " London stock (683 psi) brick; 1/2" grout.	N/A	1 hr. 52 min.			7	2	1 ³ / ₄
W-4-M-12	4 ¹ / ₂ "	4 ¹ / ₄ " × 2 ¹ / ₂ " Leicester red, wire-cut brick (4465 psi) in 1/2" sand mortar.	N/A	1 hr. 56 min.			7	6	1 ³ / ₄
W-4-M-13	4 ¹ / ₄ "	4 ¹ / ₄ " × 2 ¹ / ₂ " stairfoot brick (7527 psi) 1/2" sand mortar.	N/A	1 hr. 37 min.			7	2	1 ¹ / ₂
W-4-M-14	4 ¹ / ₄ "	4 ¹ / ₄ " × 2 ¹ / ₂ " sand-lime brick (2603 psi) 1/2" sand mortar.	N/A	2 hrs. 6 min.			7	2	2
W-4-M-15	4 ¹ / ₄ "	4 ¹ / ₄ " × 2 ¹ / ₂ " concrete brick (2527 psi) 1/2" sand mortar.	N/A	2 hrs. 10 min.			7	2	2
W-4-M-16	4 ¹ / ₂ "	4" thick clay tile; Ohio fire clay; single cell thick; No plaster exposed face; 1/2" 1:2 gypsum back face; Design "F," Construction "S."	N/A	31 min.			2	3-6, 36	1/2
W-4-M-17	4 ¹ / ₂ "	4" thick clay tile; Ohio fire clay; single cell thick; Plaster exposed face; 1/2" 1:2 sanded gypsum; Back Face: none; Construction "S," Design "F."	80 psi	50 min.			2	3-5, 8, 36	3/4
W-4-M-18	4 ¹ / ₂ "	Core: solid sand-lime brick; 1/2" sanded gypsum plaster facings on both sides.	80 psi	3 hrs.		1		1, 11	3
W-4-M-19	4 ¹ / ₂ "	Core: solid sand-lime brick; 1/2" sanded gypsum plaster facings on both sides.	80 psi	2 hrs. 30 min.		1		1, 11	2 ¹ / ₂
W-4-M-20	4 ¹ / ₂ "	Core: concrete brick 1/2" of 1:3 sanded gypsum plaster facings on both sides.	80 psi	2 hrs.		1		1, 11	2
W-4-M-21	4 ¹ / ₂ "	Core: solid clay or shale brick; 1/2" thick, 1:3 sanded gypsum plaster facings on fire sides.	80 psi	1 hr. 45 min.		1		1, 2, 11	1 ³ / ₄
W-4-M-22	4 ³ / ₄ "	4" thick clay tile; Ohio fire clay; single cell thick; cells filled with cement and broken tile concrete; Plaster on exposed face; none on unexposed face; 3/4" 1:3 sanded gypsum; Design "G," Construction "E."	N/A	1 hr. 48 min.			2	2, 3-5, 9, 36	1 ³ / ₄
W-4-M-23	4 ³ / ₄ "	4" thick clay tile; Ohio fire clay; single cell thick; cells filled with cement and broken tile concrete; No plaster exposed faced; 3/4" neat gypsum plaster on unexposed face; Design "G," Construction "E."	N/A	2 hrs. 14 min.			2	2, 3-5, 9, 36	2

(Continued)

**TABLE 1.1.2—MASONRY WALLS
4" TO LESS THAN 6" THICK—continued**

ITEM CODE	THICKNESS	CONSTRUCTION DETAILS	PERFORMANCE		REFERENCE NUMBER			NOTES	REC. HOURS
			LOAD	TIME	PRE-BMS-92	BMS-92	POST-BMS-92		
W-5-M-24	5"	3" × 13" air space; 1" thick metal reinforced concrete facings on both sides; faces connected with wood splines.	2,250 lbs./ft.	45 min.		1		1	3/4
W-5-M-25	5"	Core: 3" thick void filled with "nondulated" mineral wool weighing 10 lbs./ft. ³ ; 1" thick metal reinforced concrete facings on both sides.	2,250 lbs./ft.	2 hrs.		1		1	2
W-5-M-26	5"	Core: solid clay or shale brick; 1/2" thick, 1:3 sanded gypsum plaster facings on both sides.	40 psi	2 hrs. 30 min.		1		1, 2, 11	2 1/2
W-5-M-27	5"	Core: solid 4" thick gypsum blocks, laid in 1:3 sanded gypsum mortar; 1/2" of 1:3 sanded gypsum plaster facings on both sides.	N/A	3 hrs.		1		1	3
W-5-M-28	5"	Core: 4" thick hollow gypsum blocks with 30% voids; blocks laid in 1:3 sanded gypsum mortar; No facings.	N/A	4 hrs.		1		1	4
W-5-M-29	5"	Core: concrete brick; 1/2" of 1:3 sanded gypsum plaster facings on both sides.	160 psi	3 hrs.		1		1	3
W-5-M-30	5 1/4"	4" thick clay tile; Illinois surface clay; double cell thick; Plaster: 5/8" sanded gypsum 1:3 both faces; Design "D," Construction "S."	N/A	2 hrs. 53 min.			2	2-5, 9, 36	2 3/4
W-5-M-31	5 1/4"	4" thick clay tile; New Jersey fire clay; double cell thick; Plaster: 5/8" sanded gypsum 1:3 both faces; Design "D," Construction "S."	N/A	1 hr. 52 min.			2	2-5, 9, 36	1 3/4
W-5-M-32	5 1/4"	4" thick clay tile; New Jersey fire clay; single cell thick; Plaster: 5/8" sanded gypsum 1:3 both faces; Design "D," Construction "S."	N/A	1 hr. 34 min.	2		2	2-5, 9, 36	1 1/2
W-5-M-33	5 1/4"	4" thick clay tile; New Jersey fire clay; single cell thick; Face plaster: 5/8" both sides; 1:3 sanded gypsum; Design "B," Construction "S."	N/A	50 min.			2	3-5, 8, 36	3/4
W-5-M-34	5 1/4"	4" thick clay tile; Ohio fire clay; single cell thick; Face plaster: 5/8" both sides; 1:3 sanded gypsum; Design "B," Construction "A."	N/A	1 hr. 19 min.			2	2-5, 9, 36	1 1/4
W-5-M-35	5 1/4"	4" thick clay tile; Illinois surface clay; single cell thick; Face plaster: 5/8" both sides; 1:3 sanded gypsum; Design "B," Construction "S."	N/A	1 hr. 59 min.			2	2-5, 10 36	1 3/4
W-5-M-36	4"	Core: structural clay tile; see Notes 12, 16, 21; No facings.	N/A	15 min.		1		3, 4, 24	1/4

(Continued)

**TABLE 1.1.2—MASONRY WALLS
4" TO LESS THAN 6" THICK—continued**

ITEM CODE	THICKNESS	CONSTRUCTION DETAILS	PERFORMANCE		REFERENCE NUMBER			NOTES	REC. HOURS
			LOAD	TIME	PRE-BMS-92	BMS-92	POST-BMS-92		
W-4-M-37	4"	Core: structural clay tile; see Notes 12, 17, 21; No facings.	N/A	25 min.		1		3, 4, 24	1/3
W-4-M-38	4"	Core: structural clay tile; see Notes 12, 16, 20; No facings.	N/A	10 min.		1		3, 4, 24	1/6
W-4-M-39	4"	Core: structural clay tile; see Notes 12, 17, 20; No facings.	N/A	20 min.		1		3, 4, 24	1/3
W-4-M-40	4"	Core: structural clay tile; see Notes 13, 16, 23; No facings.	N/A	30 min.		1		3, 4, 24	1/2
W-4-M-41	4"	Core: structural clay tile; see Notes 13, 17, 23; No facings.	N/A	35 min.		1		3, 4, 24	1/2
W-4-M-42	4"	Core: structural clay tile; see Notes 13, 16, 21; No facings.	N/A	25 min.		1		3, 4, 24	1/3
W-4-M-43	4"	Core: structural clay tile; see Notes 13, 17, 21; No facings.	N/A	30 min.		1		3, 4, 24	1/2
W-4-M-44	4"	Core: structural clay tile; see Notes 15, 16, 20; No facings	N/A	1 hr. 15 min.		1		3, 4, 24	1 1/4
W-4-M-45	4"	Core: structural clay tile; see Notes 15, 17, 20; No facings.	N/A	1 hr. 15 min.		1		3, 4, 24	1 1/4
W-4-M-46	4"	Core: structural clay tile; see Notes 14, 16, 22; No facings.	N/A	20 min.		1		3, 4, 24	1/3
W-4-M-47	4"	Core: structural clay tile; see Notes 14, 17, 22; No facings.	N/A	25 min.		1		3, 4, 24	1/3
W-4-M-48	4 1/4"	Core: structural clay tile; see Notes 12, 16, 21; Facings: both sides; see Note 18.	N/A	45 min.		1		3, 4, 24	3/4
W-4-M-49	4 1/4"	Core: structural clay tile; see Notes 12, 17, 21; Facings: both sides; see Note 18.	N/A	1 hr.		1		3, 4, 24	1
W-4-M-50	4 5/8"	Core: structural clay tile; see Notes 12, 16, 21; Facings: unexposed side only; see Note 18.	N/A	25 min.		1		3, 4, 24	1/3
W-4-M-51	4 5/8"	Core: structural clay tile; see Notes 12, 17, 21; Facings: unexposed side only; see Note 18.	N/A	30 min.		1		3, 4, 24	1/2
W-4-M-52	4 5/8"	Core: structural clay tile; see Notes 12, 16, 21; Facings: unexposed side only; see Note 18.	N/A	45 min.		1		3, 4, 24	3/4
W-4-M-53	4 5/8"	Core: structural clay tile; see Notes 12, 17, 21; Facings: fire side only; see Note 18.	N/A	1 hr.		1		3, 4, 24	1
W-4-M-54	4 5/8"	Core: structural clay tile; see Notes 12, 16, 20; Facings: unexposed side; see Note 18.	N/A	20 min.		1		3, 4, 24	1/3
W-4-M-55	4 5/8"	Core: structural clay tile; see Notes 12, 17, 20; Facings: exposed side; see Note 18.	N/A	25 min.		1		3, 4, 24	1/3
W-4-M-56	4 5/8"	Core: structural clay tile; see Notes 12, 16, 20; Facings: fire side only; see Note 18.	N/A	30 min.		1		3, 4, 24	1/2
W-4-M-57	4 5/8"	Core: structural clay tile; see Notes 12, 17, 20; Facings: fire side only; see Note 18.	N/A	45 min.		1		3, 4, 24	3/4

(Continued)

**TABLE 1.1.2—MASONRY WALLS
4" TO LESS THAN 6" THICK—continued**

ITEM CODE	THICKNESS	CONSTRUCTION DETAILS	PERFORMANCE		REFERENCE NUMBER			NOTES	REC. HOURS
			LOAD	TIME	PRE-BMS-92	BMS-92	POST-BMS-92		
W-4-M-58	4 ⁵ / ₈ "	Core: structural clay tile; see Notes 13, 16, 23; Facings: unexposed side only; see Note 18.	N/A	40 min.		1		3, 4, 24	2 ² / ₃
W-4-M-59	4 ⁵ / ₈ "	Core: structural clay tile; see Notes 13, 17, 23; Facings: unexposed side only; see Note 18.	N/A	1 hr.		1		3, 4, 24	1
W-4-M-60	4 ⁵ / ₈ "	Core: structural clay tile; see Notes 13, 16, 23; Facings: fire side only; see Note 18.	N/A	1 hr. 15 min.		1		3, 4, 24	1 ¹ / ₄
W-4-M-61	4 ⁵ / ₈ "	Core: structural clay tile; see Notes 13, 17, 23; Facings: fire side only; see Note 18.	N/A	1 hr. 30 min.		1		3, 4, 24	1 ¹ / ₂
W-4-M-62	4 ⁵ / ₈ "	Core: structural clay tile; see Notes 13, 16, 21; Facings: unexposed side only; see Note 18.	N/A	35 min.		1		3, 4, 24	1 ¹ / ₂
W-4-M-63	4 ⁵ / ₈ "	Core: structural clay tile; see Notes 13, 17, 21; Facings: unexposed face only; see Note 18.	N/A	45 min.		1		3, 4, 24	3 ³ / ₄
W-4-M-64	4 ⁵ / ₈ "	Core: structural clay tile; see Notes 13, 16, 23; Facings: exposed face only; see Note 18.	N/A	1 hr.		1		3, 4, 24	1
W-4-M-65	4 ⁵ / ₈ "	Core: structural clay tile; see Notes 13, 17, 21; Facings: exposed side only; see Note 18.	N/A	1 hr. 15 min.		1		3, 4, 24	1 ¹ / ₄
W-4-M-66	4 ⁵ / ₈ "	Core: structural clay tile; see Notes 15, 17, 20; Facings: unexposed side only; see Note 18.	N/A	1 hr. 30 min.		1		3, 4, 24	1 ¹ / ₂
W-4-M-67	4 ⁵ / ₈ "	Core: structural clay tile; see Notes 15, 16, 20; Facings: exposed side only; see Note 18.	N/A	1 hr. 45 min.		1		3, 4, 24	1 ³ / ₄
W-4-M-68	4 ⁵ / ₈ "	Core: structural clay tile; see Notes 15, 17, 20; Facings: exposed side only; see Note 18.	N/A	1 hr. 45 min.		1		3, 4, 24	1 ³ / ₄
W-4-M-69	4 ⁵ / ₈ "	Core: structural clay tile; see Notes 15, 16, 20; Facings: unexposed side only; see Note 18.	N/A	1 hr. 30 min.		1		3, 4, 24	1 ³ / ₄
W-4-M-70	4 ⁵ / ₈ "	Core: structural clay tile; see Notes 14, 16, 22; Facings: unexposed side only; see Note 18.	N/A	30 min.		1		3, 4, 24	1 ¹ / ₂
W-4-M-71	4 ⁵ / ₈ "	Core: structural clay tile; see Notes 14, 17, 22; Facings: exposed side only; see Note 18.	N/A	35 min.		1		3, 4, 24	1 ¹ / ₂
W-4-M-72	4 ⁵ / ₈ "	Core: structural clay tile; see Notes 14, 16, 22; Facings: fire side of wall only; see Note 18.	N/A	45 min.		1		3, 4, 24	3 ³ / ₄
W-4-M-73	4 ⁵ / ₈ "	Core: structural clay tile; see Notes 14, 17, 22; Facings: fire side of wall only; see Note 18.	N/A	1 hr.		1		3, 4, 24	1
W-4-M-74	5 ¹ / ₄ "	Core: structural clay tile; see Notes 12, 16, 21; Facings: both sides; see Note 18.	N/A	1 hr.		1		3, 4, 24	1

(Continued)

**TABLE 1.1.2—MASONRY WALLS
4" TO LESS THAN 6" THICK—continued**

ITEM CODE	THICKNESS	CONSTRUCTION DETAILS	PERFORMANCE		REFERENCE NUMBER			NOTES	REC. HOURS
			LOAD	TIME	PRE-BMS-92	BMS-92	POST-BMS-92		
W-5-M-75	5 1/4"	Core: structural clay tile; see Notes 12, 17, 21; Facings: both sides; see Note 18.	N/A	1 hr. 15 min.		1		3, 4, 24	1 1/4
W-5-M-76	5 1/4"	Core: structural clay tile; see Notes 12, 16, 20; Facings: both sides; see Note 18.	N/A	45 min.		1		3, 4, 24	3/4
W-5-M-77	5 1/4"	Core: structural clay tile; see Notes 12, 17, 20; Facings: both sides; see Note 18.	N/A	1 hr.		1		3, 4, 24	1
W-5-M-78	5 1/4"	Core: structural clay tile; see Notes 13, 16, 23; Facings: both sides of wall; see Note 18.	N/A	1 hr. 30 min.		1		3, 4, 24	1 1/2
W-5-M-79	5 1/4"	Core: structural clay tile; see Notes 13, 17, 23; Facings: both sides of wall; see Note 18.	N/A	2 hrs.		1		3, 4, 24	2
W-5-M-80	5 1/4"	Core: structural clay tile; see Notes 13, 16, 21; Facings: both sides of wall; see Note 18.	N/A	1 hr. 15 min.		1		3, 4, 24	1 1/4
W-5-M-81	5 1/4"	Core: structural clay tile; see Notes 13, 16, 21; Facings: both sides of wall; see Note 18.	N/A	1 hr. 30 min.		1		3, 4, 24	1 1/2
W-5-M-82	5 1/4"	Core: structural clay tile; see Notes 15, 16, 20; Facings: both sides; see Note 18.	N/A	2 hrs. 30 min.		1		3, 4, 24	2 1/2
W-5-M-83	5 1/4"	Core: structural clay tile; see Notes 15, 17, 20; Facings: both sides; see Note 18.	N/A	2 hrs. 30 min.		1		3, 4, 24	2 1/2
W-5-M-84	5 1/4"	Core: structural clay tile; see Notes 14, 16, 22; Facings: both sides of wall; see Note 18.	N/A	1 hr. 15 min.		1		3, 4, 24	1 1/4
W-5-M-85	5 1/4"	Core: structural clay tile; see Notes 14, 17, 22; Facings: both sides of wall; see Note 18.	N/A	1 hr. 30 min.		1		3, 4, 24	1 1/2
W-4-M-86	4"	Core: 3" thick gypsum blocks 70% solid; see Note 26; Facings: both sides; see Note 25.	N/A	2 hrs.		1			2
W-4-M-87	4"	Core: hollow concrete units; see Notes 27, 34, 35; No facings.	N/A	1 hr. 30 min.		1			1 1/2
W-4-M-88	4"	Core: hollow concrete units; see Notes 28, 33, 35; No facings.	N/A	1 hr.		1			1
W-4-M-89	4"	Core: hollow concrete units; see Notes 28, 34, 35; Facings: both sides; see Note 25.	N/A	1 hr. 45 min.		1			1 3/4
W-4-M-90	4"	Core: hollow concrete units; see Notes 27, 34, 35; Facings: both sides; see Note 25.	N/A	2 hrs.		1			2
W-4-M-91	4"	Core: hollow concrete units; see Notes 27, 32, 35; No facings.	N/A	1 hr. 15 min.		1			1 1/4
W-4-M-92	4"	Core: hollow concrete units; see Notes 28, 34, 35; No facings.	N/A	1 hr. 15 min.		1			1 1/4
W-4-M-93	4"	Core: hollow concrete units; see Notes 29, 32, 35; No facings.	N/A	20 min.		1			1/3

(Continued)

**TABLE 1.1.2—MASONRY WALLS
4" TO LESS THAN 6" THICK—continued**

ITEM CODE	THICKNESS	CONSTRUCTION DETAILS	PERFORMANCE		REFERENCE NUMBER			NOTES	REC. HOURS
			LOAD	TIME	PRE-BMS-92	BMS-92	POST-BMS-92		
W-4-M-94	4"	Core: hollow concrete units; see Notes 30, 34, 35; No facings.	N/A	15 min.		1			1/4
W-4-M-95	4 1/2"	Core: hollow concrete units; see Notes 27, 34, 35; Facings: one side only; see Note 25.	N/A	2 hrs.		1			2
W-4-M-96	4 1/2"	Core: hollow concrete units; see Notes 27, 32, 35; Facings: one side only; see Note 25.	N/A	1 hr. 45 min.		1			1 3/4
W-4-M-97	4 1/2"	Core: hollow concrete units; see Notes 28, 33, 35; Facings: one side; see Note 25.	N/A	1 hr. 30 min.		1			1 1/2
W-4-M-98	4 1/2"	Core: hollow concrete units; see Notes 28, 34, 35; Facings: one side only; see Note 25.	N/A	1 hr. 45 min.		1			1 3/4
W-4-M-99	4 1/2"	Core: hollow concrete units; see Notes 29, 32, 35; Facings: one side; see Note 25.	N/A	30 min.		1			1/2
W-4-M-100	4 1/2"	Core: hollow concrete units; see Notes 30, 34, 35; Facings: one side; see Note 25.	N/A	20 min.		1			1/3
W-5-M-101	5"	Core: hollow concrete units; see Notes 27, 34, 35; Facings: both sides; see Note 25.	N/A	2 hrs. 30 min.		1			2 1/2
W-5-M-102	5"	Core: hollow concrete units; see Notes 27, 32, 35; Facings: both sides; see Note 25.	N/A	2 hrs. 30 min.		1			2 1/2
W-5-M-103	5"	Core: hollow concrete units; see Notes 28, 33, 35; Facings: both sides; see Note 25.	N/A	2 hrs.		1			2
W-5-M-104	5"	Core: hollow concrete units; see Notes 28, 31, 35; Facings: both sides; see Note 25.	N/A	2 hrs.		1			2
W-5-M-105	5"	Core: hollow concrete units; see Notes 29, 32, 35; Facings: both sides; see Note 25.	N/A	1 hr. 45 min.		1			1 3/4
W-5-M-106	5"	Core: hollow concrete units; see Notes 30, 34, 35; Facings: both sides; see Note 25.	N/A	1 hr.		1			1
W-5-M-107	5"	Core: 5" thick solid gypsum blocks; see Note 26; No facings.	N/A	4 hrs.		1			4
W-5-M-108	5"	Core: 4" thick hollow gypsum blocks; see Note 26; Facings: both sides; see Note 25.	N/A	3 hrs.		1			3
W-5-M-109	4"	Concrete with 4" x 4" No. 6 welded wire mesh at wall center.	100 psi	45 min.			43	2	3/4

(Continued)

**TABLE 1.1.2—MASONRY WALLS
4" TO LESS THAN 6" THICK—continued**

ITEM CODE	THICKNESS	CONSTRUCTION DETAILS	PERFORMANCE		REFERENCE NUMBER			NOTES	REC. HOURS
			LOAD	TIME	PRE-BMS-92	BMS-92	POST-BMS-92		
W-4-M-110	4"	Concrete with 4" × 4" No. 6 welded wire mesh at wall center.	N/A	1 hr. 15 min.			43	2	1 ¹ / ₄

For SI: 1 inch = 25.4 mm, 1 pound per square inch = 0.00689 MPa.

Notes:

1. Tested as NBS under ASA Spec. No. A 2-1934.
2. Failure mode - maximum temperature rise.
3. Treated at NBS under ASA Spec. No. 42-1934 (ASTM C 19-53) except that hose stream testing where carried out was run on test specimens exposed for full test duration, not for or reduced period as is contemporarily done.
4. For clay tile walls, unless the source the clay can be positively identified, it is suggested that the most pessimistic hour rating for the fire endurance of a clay tile partition of that thickness to be followed. Identified sources of clay showing longer fire endurance can lead to longer time recommendations.
5. See appendix for construction and design details for clay tile walls.
6. Failure mode - flame thru or crack formation showing flames.
7. Hole formed at 25 minutes; partition collapsed at 42 minutes or removal from furnace.
8. Failure mode - collapse.
9. Hose stream pass.
10. Hose stream hole formed in specimen.
11. Load: 80 psi for gross wall cross sectional area.
12. One cell in wall thickness.
13. Two cells in wall thickness.
14. Double cells plus one cell in wall thickness.
15. One cell in wall thickness, cells filled with broken tile, crushed stone, slag, cinders or sand mixed with mortar.
16. Dense hard-burned clay or shale tile.
17. Medium-burned clay tile.
18. Not less than 5/8 inch thickness of 1:3 sanded gypsum plaster.
19. Units of not less than 30 percent solid material.
20. Units of not less than 40 percent solid material.
21. Units of not less than 50 percent solid material.
22. Units of not less than 45 percent solid material.
23. Units of not less than 60 percent solid material.
24. All tiles laid in portland cement-lime mortar.
25. Minimum 1/2 inch - 1:3 sanded gypsum plaster.
26. Laid in 1:3 sanded gypsum mortar. Voids in hollow units not to exceed 30 percent.
27. Units of expanded slag or pumice aggregate.
28. Units of crushed limestone, blast furnace slag, cinders and expanded clay or shale.
29. Units of calcareous sand and gravel. Coarse aggregate, 60 percent or more calcite and dolomite.
30. Units of siliceous sand and gravel. Ninety percent or more quartz, chert or flint.
31. Unit at least 49 percent solid.
32. Unit at least 62 percent solid.
33. Unit at least 65 percent solid.
34. Unit at least 73 percent solid.
35. Ratings based on one unit and one cell in wall thickness.
36. See Clay Tile Partition Design Construction drawings, below.

(Continued)

**TABLE 1.1.2—MASONRY WALLS
4" TO LESS THAN 6" THICK—continued**

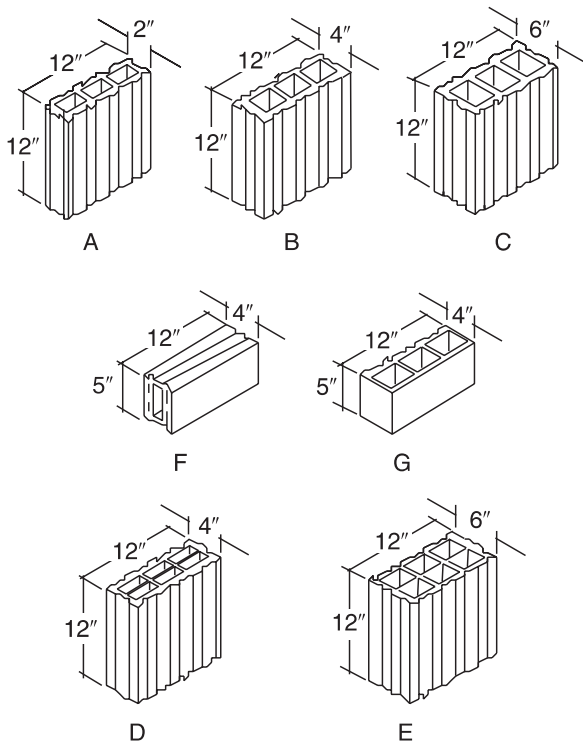

DESIGNS OF TILES USED IN FIRE-TEST PARTITIONS

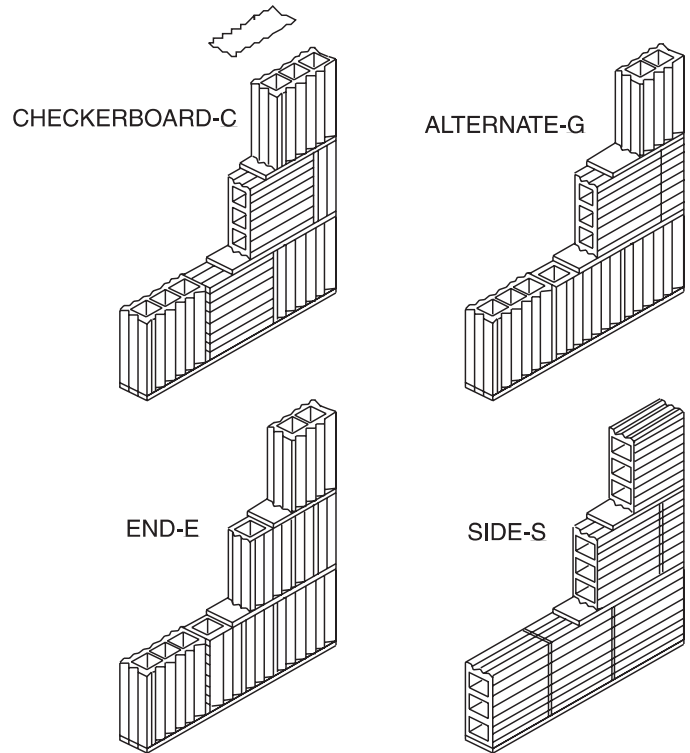

THE FOUR TYPES OF CONSTRUCTION USED
IN FIRE-TEST PARTITIONS

**FIGURE 1.1.3—MASONRY WALLS
6" TO LESS THAN 8" THICK**

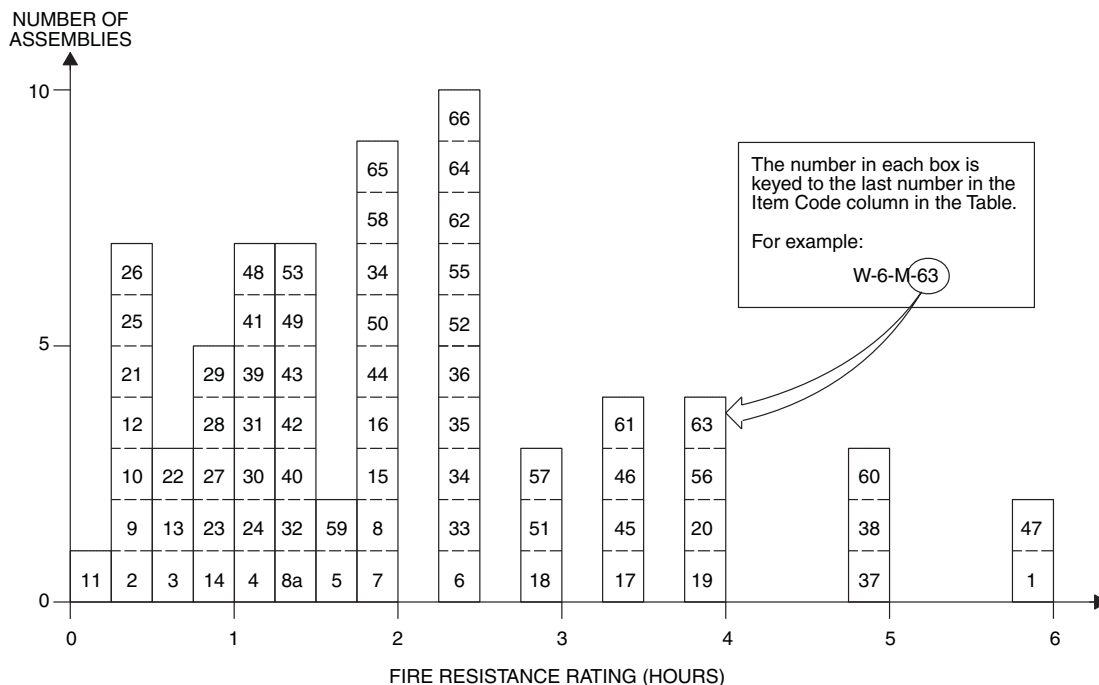

**TABLE 1.1.3—MASONRY WALLS
6" TO LESS THAN 8" THICK**

ITEM CODE	THICKNESS	CONSTRUCTION DETAILS	PERFORMANCE		REFERENCE NUMBER			NOTES	REC. HOURS
			LOAD	TIME	PRE-BMS-92	BMS-92	POST-BMS-92		
W-6-M-1	6"	Core: 5" thick, solid gypsum blocks laid in 1:3 sanded gypsum mortar; 1/2" of 1:3 sanded gypsum plaster facings on both sides.	N/A	6 hrs.		1			6
W-6-M-2	6"	6" clay tile; Ohio fire clay; single cell thick; No plaster; Design "C," Construction "A."	N/A	17 min.			2	1, 3, 4, 6, 55	1/4
W-6-M-3	6"	6" clay tile; Illinois surface clay; double cell thick; No plaster; Design "E," Construction "C."	N/A	45 min.			2	1-4, 7, 55	3/4
W-6-M-4	6"	6" clay tile; New Jersey fire clay; double cell thick; No plaster; Design "E," Construction "S."	N/A	1 hr. 1 min.			2	1-4, 8, 55	1
W-7-M-5	7 1/4"	6" clay tile; Illinois surface clay; double cell thick; Plaster: 5/8" - 1:3 sanded gypsum both faces; Design "E," Construction "A."	N/A	1 hr. 41 min.			2	1-4, 55	1 2/3
W-7-M-6	7 1/4"	6" clay tile; New Jersey fire clay; double cell thick; Plaster: 5/8" - 1:3 sanded gypsum both faces; Design "E," Construction "S."	N/A	2 hrs. 23 min.			2	1-4, 9, 55	2 1/3
W-7-M-7	7 1/4"	6" clay tile; Ohio fire clay; single cell thick; Plaster: 5/8" sanded gypsum; 1:3 both faces; Design "C," Construction "A."	N/A	1 hr. 54 min.			2	1-4, 9, 55	2 3/4

(Continued)

**TABLE 1.1.3—MASONRY WALLS
6" TO LESS THAN 8" THICK—continued**

ITEM CODE	THICKNESS	CONSTRUCTION DETAILS	PERFORMANCE		REFERENCE NUMBER			NOTES	REC. HOURS
			LOAD	TIME	PRE-BMS-92	BMS-92	POST-BMS-92		
W-7-M-8	7 1/4"	6" clay tile; Illinois surface clay; single cell thick; Plaster: 5/8" sanded gypsum 1:3 both faces; Design "C," Construction "S."	N/A	2 hrs.			2	1, 3, 4, 9, 10, 55	2
W-7-M-8a	7 1/4"	6" clay tile; Illinois surface clay; single cell thick; Plaster: 5/8" sanded gypsum 1:3 both faces; Design "C," Construction "E."	N/A	1 hr. 23 min			2	1-4, 9, 10, 55	1 3/4
W-6-M-9	6"	Core: structural clay tile; see Notes 12, 16, 20; No facings.	N/A	20 min.		1		3, 5, 24	1/3
W-6-M-10	6"	Core: structural clay tile; see Notes 12, 17, 20; No facings.	N/A	25 min.		1		3, 5, 24	1/3
W-6-M-11	6"	Core: structural clay tile; see Notes 12, 16, 19; No facings.	N/A	15 min.		1		3, 5, 24	1/4
W-6-M-12	6"	Core: structural clay tile; see Notes 12, 17, 19; No facings.	N/A	20 min.		1		3, 5, 24	1/3
W-6-M-13	6"	Core: structural clay tile; see Notes 13, 16, 22; No facings.	N/A	45 min.		1		3, 5, 24	3/4
W-6-M-14	6"	Core: structural clay tile; see Notes 13, 17, 22; No facings.	N/A	1 hr.		1		3, 5, 24	1
W-6-M-15	6"	Core: structural clay tile; see Notes 15, 17, 19; No facings.	N/A	2 hrs.		1		3, 5, 24	2
W-6-M-16	6"	Core: structural clay tile; see Notes 15, 16, 19; No facings.	N/A	2 hrs.		1		3, 5, 24	2
W-6-M-17	6"	Cored concrete masonry; see Notes 12, 34, 36, 38, 41; No facings.	80 psi	3 hrs. 30 min.		1		5, 25	3 1/2
W-6-M-18	6"	Cored concrete masonry; see Notes 12, 33, 36, 38, 41; No facings.	80 psi	3 hrs.		1		5, 25	3
W-6-M-19	6 1/2"	Cored concrete masonry; see Notes 12, 34, 36, 38, 41; Facings: side 1; see Note 35.	80 psi	4 hrs.		1		5, 25	4
W-6-M-20	6 1/2"	Cored concrete masonry; see Notes 12, 33, 36, 38, 41; Facings: side 1; see Note 35.	80 psi	4 hrs.		1		5, 25	4
W-6-M-21	6 5/8"	Core: structural clay tile; see Notes 12, 16, 20; Facings: unexposed face only; see Note 18.	N/A	30 min.		1		3, 5, 24	1/2
W-6-M-22	6 5/8"	Core: structural clay tile; see Notes 12, 17, 20; Facings: unexposed face only; see Note 18.	N/A	40 min.		1		3, 5, 24	2/3
W-6-M-23	6 5/8"	Core: structural clay tile; see Notes 12, 16, 20; Facings: exposed face only; see Note 18.	N/A	1 hr.		1		3, 5, 24	1
W-6-M-24	6 5/8"	Core: structural clay tile; see Notes 12, 17, 20; Facings: exposed face only; see Note 18.	N/A	1 hr. 5 min.		1		3, 5, 24	1
W-6-M-25	6 5/8"	Core: structural clay tile; see Notes 12, 16, 19; Facings: unexposed side only; see Note 18.	N/A	25 min.		1		3, 5, 24	1/3

(Continued)

**TABLE 1.1.3—MASONRY WALLS
6" TO LESS THAN 8" THICK—continued**

ITEM CODE	THICKNESS	CONSTRUCTION DETAILS	PERFORMANCE		REFERENCE NUMBER			NOTES	REC. HOURS
			LOAD	TIME	PRE-BMS-92	BMS-92	POST-BMS-92		
W-6-M-26	6 ⁵ / ₈ "	Core: structural clay tile; see Notes 12, 7, 19; Facings: unexposed face only; see Note 18.	N/A	30 min.		1		3, 5, 24	1/2
W-6-M-27	6 ⁵ / ₈ "	Core: structural clay tile; see Notes 12, 16, 19; Facings: exposed side only; see Note 18.	N/A	1 hr.		1		3, 5, 24	1
W-6-M-28	6 ⁵ / ₈ "	Core: structural clay tile; see Notes 12, 17, 19; Facings: fire side only; see Note 18.	N/A	1 hr.		1		3, 5, 24	1
W-6-M-29	6 ⁵ / ₈ "	Core: structural clay tile; see Notes 13, 16, 22; Facings: unexposed side only; see Note 18.	N/A	1 hr.		1		3, 5, 24	1
W-6-M-30	6 ⁵ / ₈ "	Core: structural clay tile; see Notes 13, 17, 22; Facings: unexposed side only; see Note 18.	N/A	1 hr. 15 min.		1		3, 5, 24	1 1/4
W-6-M-31	6 ⁵ / ₈ "	Core: structural clay tile; see Notes 13, 16, 22; Facings: fire side only; see Note 18.	N/A	1 hr. 15 min.		1		3, 5, 24	1 1/4
W-6-M-32	6 ⁵ / ₈ "	Core: structural clay tile; see Notes 13, 17, 22; Facings: fire side only; see Note 18.	N/A	1 hr. 30 min.		1		3, 5, 24	1 1/2
W-6-M-33	6 ⁵ / ₈ "	Core: structural clay tile; see Notes 15, 16, 19; Facings: unexposed side only; see Note 18.	N/A	2 hrs. 30 min.		1		3, 5, 24	2 1/2
W-6-M-34	6 ⁵ / ₈ "	Core: structural clay tile; see Notes 15, 17, 19; Facings: unexposed side only; see Note 18.	N/A	2 hrs. 30 min.		1		3, 5, 24	2 1/2
W-6-M-35	6 ⁵ / ₈ "	Core: structural clay tile; see Notes 15, 16, 19; Facings: fire side only; see Note 18.	N/A	2 hrs. 30 min.		1		3, 5, 24	2 1/2
W-6-M-36	6 ⁵ / ₈ "	Core: structural clay tile; see Notes 15, 17, 19; Facings: fire side only; see Note 18.	N/A	2 hrs. 30 min.		1		3, 5, 24	2 1/2
W-6-M-37	7"	Cored concrete masonry; see Notes 12, 34, 36, 38, 41; see Note 35 for facings on both sides.	80 psi	5 hrs.		1		5, 25	5
W-6-M-38	7"	Cored concrete masonry; see Notes 12, 33, 36, 38, 41; see Note 35 for facings.	80 psi	5 hrs.		1		5, 25	5
W-6-M-39	7 1/4"	Core: structural clay tile; see Notes 12, 16, 20; Facings: both sides; see Note 18.	N/A	1 hr. 15 min.		1		3, 5, 24	1 1/4
W-6-M-40	7 1/4"	Core: structural clay tile; see Notes 12, 17, 20; Facings: both sides; see Note 18.	N/A	1 hr. 30 min.		1		3, 5, 24	1 1/2
W-6-M-41	7 1/4"	Core: structural clay tile; see Notes 12, 16, 19; Facings: both sides; see Note 18.	N/A	1 hr. 15 min.		1		3, 5, 24	1 1/4
W-6-M-42	7 1/4"	Core: structural clay tile; see Notes 12, 17, 19; Facings: both sides; see Note 18.	N/A	1 hr. 30 min.		1		3, 5, 24	1 1/2

(Continued)

**TABLE 1.1.3—MASONRY WALLS
6" TO LESS THAN 8" THICK—continued**

ITEM CODE	THICKNESS	CONSTRUCTION DETAILS	PERFORMANCE		REFERENCE NUMBER			NOTES	REC. HOURS
			LOAD	TIME	PRE-BMS-92	BMS-92	POST-BMS-92		
W-7-M-43	7 ¹ / ₄ "	Core: structural clay tile; see Notes 13, 16, 22; Facings: both sides of wall; see Note 18.	N/A	1 hr. 30 min.		1		3, 5, 24	1 ¹ / ₂
W-7-M-44	7 ¹ / ₄ "	Core: structural clay tile; see Notes 13, 17, 22; Facings: both sides of wall; see Note 18.	N/A	2 hrs.		1		3, 5, 24	1 ¹ / ₂
W-7-M-45	7 ¹ / ₄ "	Core: structural clay tile; see Notes 15, 16, 19; Facings: both sides; see Note 18.	N/A	3 hrs. 30 min.		1		3, 5, 24	3 ¹ / ₂
W-7-M-46	7 ¹ / ₄ "	Core: structural clay tile; see Notes 15, 17, 19; Facings: both sides; see Note 18.	N/A	3 hrs. 30 min.		1		3, 5, 24	3 ¹ / ₂
W-6-M-47	6"	Core: 5" thick solid gypsum blocks; see Note 45; Facings: both sides; see Note 45.	N/A	6 hrs.		1			6
W-6-M-48	6"	Core: hollow concrete units; see Notes 47, 50, 54; No facings.	N/A	1 hr. 15 min.		1			1 ¹ / ₄
W-6-M-49	6"	Core: hollow concrete units; see Notes 46, 50, 54; No facings.	N/A	1 hr. 30 min.		1			1 ¹ / ₂
W-6-M-50	6"	Core: hollow concrete units; see Notes 46, 41, 54; No facings.	N/A	2 hrs.		1			2
W-6-M-51	6"	Core: hollow concrete units; see Notes 46, 53, 54; No facings.	N/A	3 hrs.		1			3
W-6-M-52	6"	Core: hollow concrete units; see Notes 47, 53, 54; No facings.	N/A	2 hrs. 30 min.		1			2 ¹ / ₂
W-6-M-53	6"	Core: hollow concrete units; see Notes 47, 51, 54; No facings.	N/A	1 hr. 30 min.		1			1 ¹ / ₂
W-6-M-54	6 ¹ / ₂ "	Core: hollow concrete units; see Notes 46, 50, 54; Facings: one side only; see Note 35.	N/A	2 hrs.		1			2
W-6-M-55	6 ¹ / ₂ "	Core: hollow concrete units; see Notes 4, 51, 54; Facings: one side; see Note 35.	N/A	2 hrs. 30 min.		1			2 ¹ / ₂
W-6-M-56	6 ¹ / ₂ "	Core: hollow concrete units; see Notes 46, 53, 54; Facings: one side; see Note 35.	N/A	4 hrs.		1			4
W-6-M-57	6 ¹ / ₂ "	Core: hollow concrete units; see Notes 47, 53, 54; Facings: one side; see Note 35.	N/A	3 hrs.		1			3
W-6-M-58	6 ¹ / ₂ "	Core: hollow concrete units; see Notes 47, 51, 54; Facings: one side; see Note 35.	N/A	2 hrs.		1			2
W-6-M-59	6 ¹ / ₂ "	Core: hollow concrete units; see Notes 47, 50, 54; Facings: one side; see Note 35.	N/A	1 hr. 45 min.		1			1 ³ / ₄
W-7-M-60	7"	Core: hollow concrete units; see Notes 46, 53, 54; Facings: both sides; see Note 35.	N/A	5 hrs.		1			5
W-7-M-61	7"	Core: hollow concrete units; see Notes 46, 51, 54; Facings: both sides; see Note 35.	N/A	3 hrs. 30 min.		1			3 ¹ / ₂

(Continued)

**TABLE 1.1.3—MASONRY WALLS
6" TO LESS THAN 8" THICK—continued**

ITEM CODE	THICKNESS	CONSTRUCTION DETAILS	PERFORMANCE		REFERENCE NUMBER			NOTES	REC. HOURS
			LOAD	TIME	PRE-BMS-92	BMS-92	POST-BMS-92		
W-7-M-62	7"	Core: hollow concrete units; see Notes 46, 50, 54; Facings: both sides; see Note 35.	N/A	2 hrs. 30 min.		1			2½
W-7-M-63	7"	Core: hollow concrete units; see Notes 47, 53, 54; Facings: both sides; see Note 35.	N/A	4 hrs.		1			4
W-7-M-64	7"	Core: hollow concrete units; see Notes 47, 51, 54; Facings: both sides; see Note 35.	N/A	2 hrs. 30 min.		1			2½
W-7-M-65	7"	Core: hollow concrete units; see Notes 47, 50, 54; Facings: both sides; see Note 35.	N/A	2 hrs.		1			2
W-6-M-66	6"	Concrete wall with 4" × 4" No. 6 wire fabric (welded) near wall center for reinforcement.	N/A	2 hrs. 30 min.			43	2	2½

For SI: 1 inch = 25.4 mm, 1 pound per square inch = 0.00689 MPa.

Notes:

1. Tested at NBS under ASA Spec. No. 43-1934 (ASTM C 19-53) except that hose stream testing where carried out was run on test specimens exposed for full test duration, not for a reduced period as is contemporarily done.
2. Failure by thermal criteria - maximum temperature rise.
3. For clay tile walls, unless the source or density of the clay can be positively identified or determined, it is suggested that the lowest hourly rating for the fire endurance of a clay tile partition of that thickness be followed. Identified sources of clay showing longer fire endurance can lead to longer time recommendations.
4. See Note 55 for construction and design details for clay tile walls.
5. Tested at NBS under ASA Spec. No. A2-1934.
6. Failure mode - collapse.
7. Collapsed on removal from furnace at 1 hour 9 minutes.
8. Hose stream - failed.
9. Hose stream - passed.
10. No end point met in test.
11. Wall collapsed at 1 hour 28 minutes.
12. One cell in wall thickness.
13. Two cells in wall thickness.
14. Double shells plus one cell in wall thickness.
15. One cell in wall thickness, cells filled with broken tile, crushed stone, slag, cinders or sand mixed with mortar.
16. Dense hard-burned clay or shale tile.
17. Medium-burned clay tile.
18. Not less than 5/8 inch thickness of 1:3 sanded gypsum plaster.
19. Units of not less than 30 percent solid material.
20. Units of not less than 40 percent solid material.
21. Units of not less than 50 percent solid material.
22. Units of not less than 45 percent solid material.
23. Units of not less than 60 percent solid material.
24. All tiles laid in portland cement-lime mortar.
25. Load: 80 psi for gross cross sectional area of wall.
26. Three cells in wall thickness.
27. Minimum percent of solid material in concrete units = 52%.
28. Minimum percent of solid material in concrete units = 54%.
29. Minimum percent of solid material in concrete units = 55%.
30. Minimum percent of solid material in concrete units = 57%.
31. Minimum percent of solid material in concrete units = 62%.
32. Minimum percent of solid material in concrete units = 65%.
33. Minimum percent of solid material in concrete units = 70%.
34. Minimum percent of solid material in concrete units = 76%.
35. Not less than 1/2 inch of 1:3 sanded gypsum plaster.
36. Noncombustible or no members framed into wall.
37. Combustible members framed into wall.
38. One unit in wall thickness.
39. Two units in wall thickness.

(Continued)

**TABLE 1.1.3—MASONRY WALLS
6" TO LESS THAN 8" THICK—continued**

- 40. Three units in wall thickness.
- 41. Concrete units made with expanded slag or pumice aggregates.
- 42. Concrete units made with expanded burned clay or shale, crushed limestone, air cooled slag or cinders.
- 43. Concrete units made with calcareous sand and gravel. Coarse aggregate, 60 percent or more calcite and dolomite.
- 44. Concrete units made with siliceous sand and gravel. Ninety percent or more quartz, chert or flint.
- 45. Laid in 1:3 sanded gypsum mortar.
- 46. Units of expanded slag or pumice aggregate.
- 47. Units of crushed limestone, blast furnace, slag, cinder and expanded clay or shale.
- 48. Units of calcareous sand and gravel. Coarse aggregate, 60 percent or more calcite and dolomite.
- 49. Units of siliceous sand and gravel. Ninety percent or more quartz, chert or flint.
- 50. Unit minimum 49 percent solid.
- 51. Unit minimum 62 percent solid.
- 52. Unit minimum 65 percent solid.
- 53. Unit minimum 73 percent solid.
- 54. Ratings based on one unit and one cell in wall section.
- 55. See Clay Tile Partition Design Construction drawings, below.

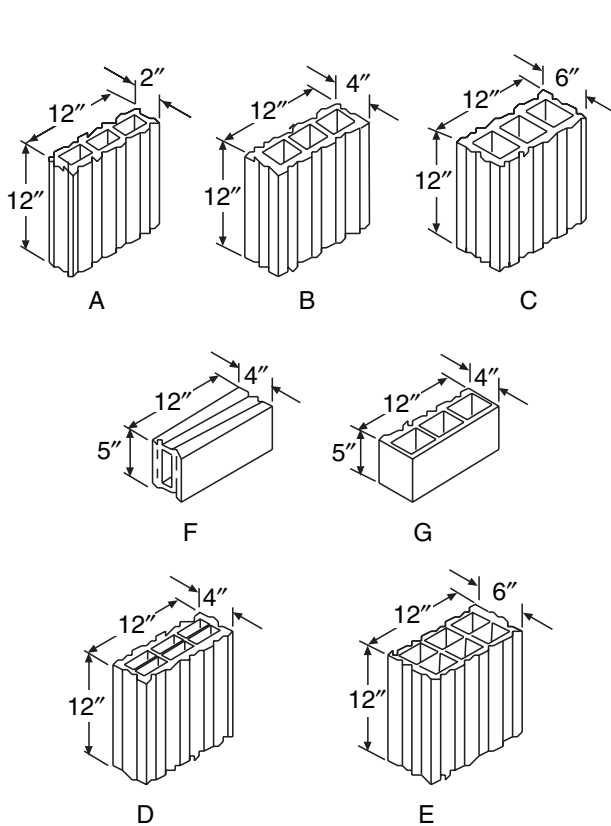

DESIGNS OF TILES USED IN FIRE-TEST PARTITIONS

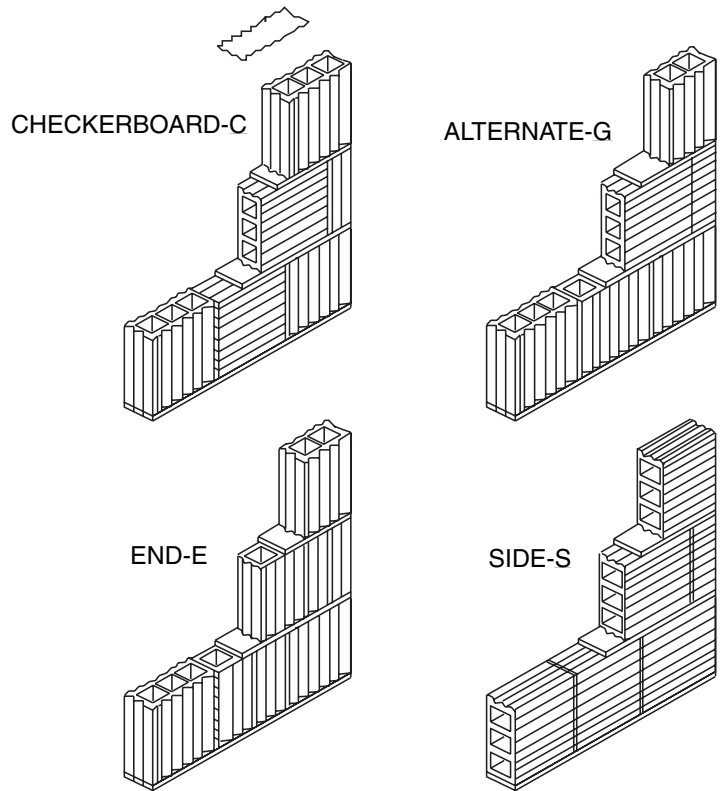

THE FOUR TYPES OF CONSTRUCTION USED IN FIRE-TEST PARTITIONS

**FIGURE 1.1.4—MASONRY WALLS
8" TO LESS THAN 10" THICK**

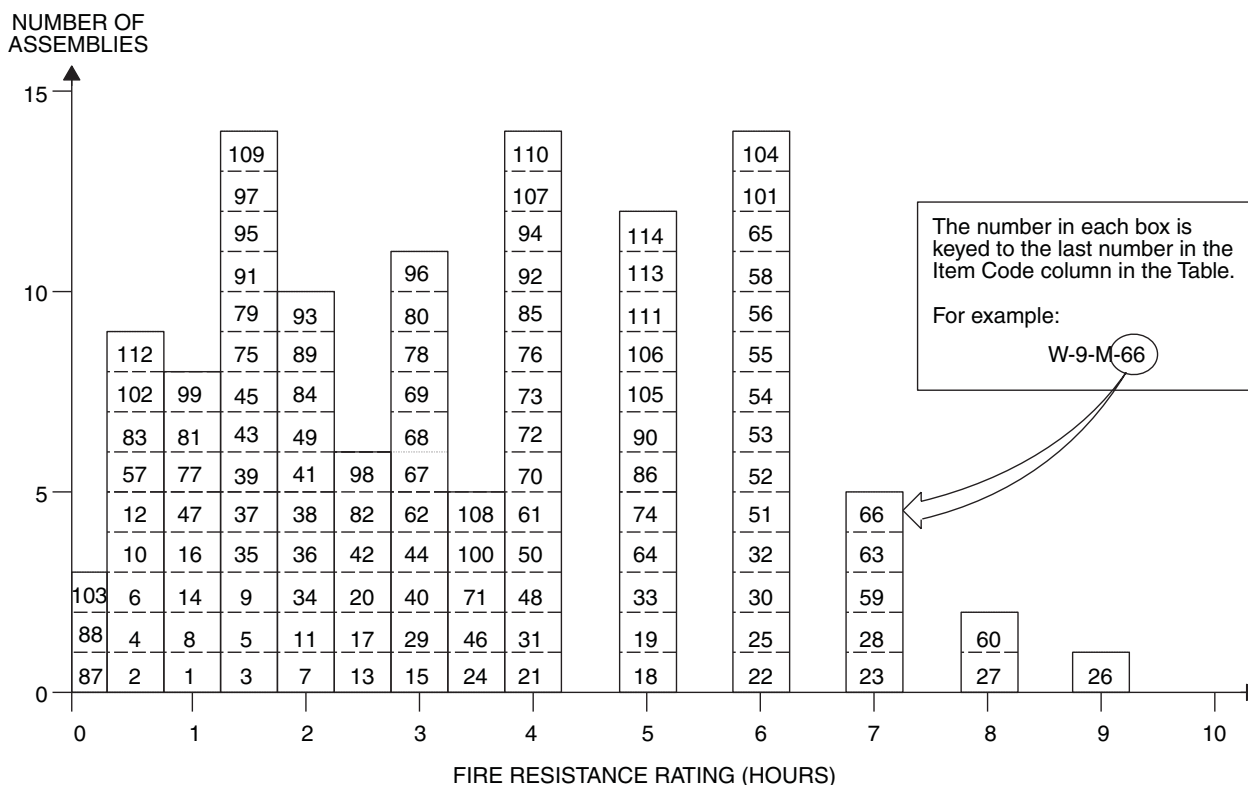

**TABLE 1.1.4—MASONRY WALLS
8" TO LESS THAN 10" THICK**

ITEM CODE	THICKNESS	CONSTRUCTION DETAILS	PERFORMANCE		REFERENCE NUMBER			NOTES	REC. HOURS
			LOAD	TIME	PRE-BMS-92	BMS-92	POST-BMS-92		
W-8-M-1	8"	Core: clay or shale structural tile; Units in wall thickness: 1; Cells in wall thickness: 2; Minimum % solids in units: 40.	80 psi	1 hr. 15 min.		1		1, 20	1 ¹ / ₄
W-8-M-2	8"	Core: clay or shale structural tile; Units in wall thickness: 1; Cells in wall thickness: 2; Minimum % solids in units: 40; No facings; Result for wall with combustible members framed into interior.	80 psi	45 min.		1		1, 20	³ / ₄
W-8-M-3	8"	Core: clay or shale structural tile; Units in wall thickness: 1; Cells in wall thickness: 2; Minimum % solids in units: 43.	80 psi	1 hr. 30 min.		1		1, 20	1 ¹ / ₂
W-8-M-4	8"	Core: clay or shale structural tile; Units in wall thickness: 1; Cells in wall thickness: 2; Minimum % solids in units: 43; No facings; Combustible members framed into wall.	80 psi	45 min.		1		1, 20	³ / ₄
W-8-M-5	8"	Core: clay or shale structural tile; No facings.	See Notes	1 hr. 30 min.		1		1, 2, 5, 10, 18, 20, 21	1 ¹ / ₂

(Continued)

**TABLE 1.1.4—MASONRY WALLS
8" TO LESS THAN 10" THICK—continued**

ITEM CODE	THICKNESS	CONSTRUCTION DETAILS	PERFORMANCE		REFERENCE NUMBER			NOTES	REC. HOURS
			LOAD	TIME	PRE-BMS-92	BMS-92	POST-BMS-92		
W-8-M-6	8"	Core: clay or shale structural tile; No facings.	See Notes	45 min.		1		1, 2, 5, 10, 19, 20, 21	3/4
W-8-M-7	8"	Core: clay or shale structural tile; No facings.	See Notes	2 hrs.		1		1, 2, 5, 13, 18, 20, 21	2
W-8-M-8	8"	Core: clay or shale structural tile; No facings.	See Notes	1 hr. 45 min.		1		1, 2, 5, 13, 19, 20, 21	1 1/4
W-8-M-9	8"	Core: clay or shale structural tile; No facings.	See Notes	1 hr. 15 min.		1		1, 2, 6, 9, 18, 20, 21	1 3/4
W-8-M-10	8"	Core: clay or shale structural tile; No facings.	See Notes	45 min.		1		1, 2, 6, 9, 19, 20, 21	3/4
W-8-M-11	8"	Core: clay or shale structural tile; No facings.	See Notes	2 hrs.		1		1, 2, 6, 10, 18, 20, 21	2
W-8-M-12	8"	Core: clay or shale structural tile; No facings.	See Notes	45 min.		1		1, 2, 6, 10, 19, 20, 21	3/4
W-8-M-13	8"	Core: clay or shale structural tile; No facings.	See Notes	2 hrs. 30 min.		1		1, 3, 6, 12, 18, 20, 21	2 1/2
W-8-M-14	8"	Core: clay or shale structural tile; No facings.	See Notes	1 hr.		1		1, 2, 6, 12, 19, 20, 21	1
W-8-M-15	8"	Core: clay or shale structural tile; No facings.	See Notes	3 hrs.		1		1, 2, 6, 16, 18, 20, 21	3
W-8-M-16	8"	Core: clay or shale structural tile; No facings.	See Notes	1 hr. 15 min.		1		1, 2, 6, 16, 19, 20, 21	1 1/4
W-8-M-17	8"	Cored clay or shale brick; Units in wall thickness: 1; Cells in wall thickness: 1; Minimum % solids: 70; No facings.	See Notes	2 hrs. 30 min.		1		1, 44	2 1/2
W-8-M-18	8"	Cored clay or shale brick; Units in wall thickness: 2; Cells in wall thickness: 2; Minimum % solids: 87; No facings.	See Notes	5 hrs.		1		1, 45	5
W-8-M-19	8"	Core: solid clay or shale brick; No facings.	See Notes	5 hrs.		1		1, 22, 45	5
W-8-M-20	8"	Core: hollow rolok of clay or shale.	See Notes	2 hrs. 30 min.		1		1, 22, 45	2 1/2
W-8-M-21	8"	Core: hollow rolok bak of clay or shale; No facings.	See Notes	4 hrs.		1		1, 45	4
W-8-M-22	8"	Core: concrete brick; No facings.	See Notes	6 hrs.		1		1, 45	6
W-8-M-23	8"	Core: sand-lime brick; No facings.	See Notes	7 hrs.		1		1, 45	7

(Continued)

**TABLE 1.1.4—MASONRY WALLS
8" TO LESS THAN 10" THICK—continued**

ITEM CODE	THICKNESS	CONSTRUCTION DETAILS	PERFORMANCE		REFERENCE NUMBER			NOTES	REC. HOURS
			LOAD	TIME	PRE-BMS-92	BMS-92	POST-BMS-92		
W-8-M-24	8"	Core: 4", 40% solid clay or shale structural tile; 1 side 4" brick facing.	See Notes	3 hrs. 30 min.		1		1, 20	3½
W-8-M-25	8"	Concrete wall (3220 psi); Reinforcing vertical rods 1" from each face and 1" diameter; horizontal rods 5/8" diameter.	22,200 lbs./ft.	6 hrs.			7		6
W-8-M-26	8"	Core: sand-line brick; 1/2" of 1:3 sanded gypsum plaster facings on one side.	See Notes	9 hrs.		1		1, 45	9
W-8-M-27	8½"	Core: sand-line brick; 1/2" of 1:3 sanded gypsum plaster facings on one side.	See Notes	8 hrs.		1		1, 45	8
W-8-M-28	8½"	Core: concrete; 1/2" of 1:3 sanded gypsum plaster facings on one side.	See Notes	7 hrs.		1		1, 45	7
W-8-M-29	8½"	Core: hollow rolok of clay or shale; 1/2" of 1:3 sanded gypsum plaster facings on one side.	See Notes	3 hrs.		1		1, 45	3
W-8-M-30	8½"	Core: solid clay or shale brick 1/2" thick, 1:3 sanded gypsum plaster facings on one side.	See Notes	6 hrs.		1		1, 22, 45,	6
W-8-M-31	8½"	Core: cored clay or shale brick; Units in wall thickness: 1; Cells in wall thickness: 1; Minimum % solids: 70; 1/2" of 1:3 sanded gypsum plaster facings on both sides.	See Notes	4 hrs.		1		1, 44	4
W-8-M-32	8½"	Core: cored clay or shale brick; Units in wall thickness: 2; Cells in wall thickness: 2; Minimum % solids: 87; 1/2" of 1:3 sanded gypsum plaster facings on one side.	See Notes	6 hrs.		1		1, 45	6
W-8-M-33	8½"	Core: hollow RoloK Bak of clay or shale; 1/2" of 1:3 sanded gypsum plaster facings on one side.	See Notes	5 hrs.		1		1, 45	5
W-8-M-34	8 ⁵ / ₈ "	Core: clay or shale structural tile; Units in wall thickness: 1; Cells in wall thickness: 2; Minimum % solids in units: 40; 5/8" of 1:3 sanded gypsum plaster facings on one side.	See Notes	2 hrs.		1		1, 20, 21	2
W-8-M-35	8 ⁵ / ₈ "	Core: clay or shale structural tile; Units in wall thickness: 1; Cells in wall thickness: 2; Minimum % solids in units: 40; Exposed face: 5/8" of 1:3 sanded gypsum plaster.	See Notes	1 hr. 30 min.		1		1, 20, 21	1½

(Continued)

**TABLE 1.1.4—MASONRY WALLS
8" TO LESS THAN 10" THICK—continued**

ITEM CODE	THICKNESS	CONSTRUCTION DETAILS	PERFORMANCE		REFERENCE NUMBER			NOTES	REC. HOURS
			LOAD	TIME	PRE-BMS-92	BMS-92	POST-BMS-92		
W-8-M-36	8 ⁵ / ₈ "	Core: clay or shale structural tile; Units in wall thickness: 1; Cells in wall thickness: 2; Minimum % solids in units: 43; 5 ⁵ / ₈ " of 1:3 sanded gypsum plaster facings on one side.	See Notes	2 hrs.				1, 20, 21	2
W-8-M-37	8 ⁵ / ₈ "	Core: clay or shale structural tile; Units in wall thickness: 1; Cells in wall thickness: 2; Minimum % solids in units: 43; 5 ⁵ / ₈ " of 1:3 sanded gypsum plaster of the exposed face only.	See Notes	1 hr. 30 min.		1		1, 20, 21	1 ¹ / ₂
W-8-M-38	8 ⁵ / ₈ "	Core: clay or shale structural tile; Facings: side 1; see Note 17.	See Notes	2 hrs.		1		1, 2, 5, 10, 18, 20, 21	2
W-8-M-39	8 ⁵ / ₈ "	Core: clay or shale structural tile; Facings: exposed side only; see Note 17.	See Notes	1 hr. 30 min.		1		1, 2, 5, 10, 19, 20, 21	1 ¹ / ₂
W-8-M-40	8 ⁵ / ₈ "	Core: clay or shale structural tile; Facings: exposed side only; see Note 17.	See Notes	3 hrs.		1		1, 2, 5, 13, 18, 20, 21	3
W-8-M-41	8 ⁵ / ₈ "	Core: clay or shale structural tile; Facings: exposed side only; see Note 17.	See Notes	2 hrs.		1		1, 2, 5, 13, 19, 20, 21	2
W-8-M-42	8 ⁵ / ₈ "	Core: clay or shale structural tile; Facings: side 1; see Note 17.	See Notes	2 hrs. 30 min.		1		1, 2, 9, 18, 20, 21	2 ¹ / ₂
W-8-M-43	8 ⁵ / ₈ "	Core: clay or shale structural tile; Facings: exposed side only; see Note 17.	See Notes	1 hr. 30 min.		1		1, 2, 6, 9, 19, 20, 21	1 ¹ / ₂
W-8-M-44	8 ⁵ / ₈ "	Core: clay or shale structural tile; Facings: side 1, see Note 17; side 2, none.	See Notes	3 hrs.		1		1, 2, 10, 18, 20, 21	3
W-8-M-45	8 ⁵ / ₈ "	Core: clay or shale structural tile; Facings: fire side only; see Note 17.	See Notes	1 hr. 30 min.		1		1, 2, 6, 10, 19, 20, 21	1 ¹ / ₂
W-8-M-46	8 ⁵ / ₈ "	Core: clay or shale structural tile; Facings: side 1, see Note 17; side 2, none.	See Notes	3 hrs. 30 min.		1		1, 2, 6, 12, 18, 20, 21	3 ¹ / ₂
W-8-M-47	8 ⁵ / ₈ "	Core: clay or shale structural tile; Facings: exposed side only; see Note 17.	See Notes	1 hr. 45 min.		1		1, 2, 6, 12, 19, 20, 21	1 ³ / ₄
W-8-M-48	8 ⁵ / ₈ "	Core: clay or shale structural tile; Facings: side 1, see Note 17; side 2, none.	See Notes	4 hrs.		1		1, 2, 6, 16, 18, 20, 21	4
W-8-M-49	8 ⁵ / ₈ "	Core: clay or shale structural tile; Facings: fire side only; see Note 17.	See Notes	2 hrs.		1		1, 2, 6, 16, 19, 20, 21	2

(Continued)

**TABLE 1.1.4—MASONRY WALLS
8" TO LESS THAN 10" THICK—continued**

ITEM CODE	THICKNESS	CONSTRUCTION DETAILS	PERFORMANCE		REFERENCE NUMBER			NOTES	REC. HOURS
			LOAD	TIME	PRE-BMS-92	BMS-92	POST-BMS-92		
W-8-M-50	8 ⁵ / ₈ "	Core: 4", 40% solid clay or shale clay structural tile; 4" brick plus 5 ⁵ / ₈ " of 1:3 sanded gypsum plaster facings on one side.	See Notes	4 hrs.		1		1, 20	4
W-8-M-51	8 ³ / ₄ "	8 ³ / ₄ " × 2 ¹ / ₂ " and 4" × 2 ¹ / ₂ " cellular fletton (1873 psi) single and triple cell hollow brick set in 1 ¹ / ₂ " sand mortar in alternate courses.	3.6 tons/ft.	6 hrs.			7	23, 29	6
W-8-M-52	8 ³ / ₄ "	8 ³ / ₄ " thick cement brick (2527 psi) with P.C. and sand mortar.	3.6 tons/ft.	6 hrs.			7	23, 24	6
W-8-M-53	8 ³ / ₄ "	8 ³ / ₄ " × 2 ¹ / ₂ " fletton brick (1831 psi) in 1 ¹ / ₂ " sand mortar.	3.6 tons/ft.	6 hrs.			7	23, 24	6
W-8-M-54	8 ³ / ₄ "	8 ³ / ₄ " × 2 ¹ / ₂ " London stock brick (683 psi) in 1 ¹ / ₂ " P.C. - sand mortar.	7.2 tons/ft.	6 hrs.			7	23, 24	6
W-9-M-55	9"	9" × 2 ¹ / ₂ " Leicester red wire-cut brick (4465 psi) in 1 ¹ / ₂ " P.C. - sand mortar.	6.0 tons/ft.	6 hrs.			7	23, 24	6
W-9-M-56	9"	9" × 3" sand-lime brick (2603 psi) in 1 ¹ / ₂ " P.C. - sand mortar.	3.6 tons/ft.	6 hrs.			7	23, 24	6
W-9-M-57	9"	2 layers 2 ⁷ / ₈ " fletton brick (1910 psi) with 3 ¹ / ₄ " air space; Cement and sand mortar.	1.5 tons/ft.	32 min.			7	23, 25	1/3
W-9-M-58	9"	9" × 3" stairfoot brick (7527 psi) in 1 ¹ / ₂ " sand-cement mortar.	7.2 tons/ft.	6 hrs.			7	23, 24	6
W-9-M-59	9"	Core: solid clay or shale brick; 1/2" thick; 1:3 sanded gypsum plaster facings on both sides.	See Notes	7 hrs.		1		1, 22, 45	7
W-9-M-60	9"	Core: concrete brick; 1/2" of 1:3 sanded gypsum plaster facings on both sides.	See Notes	8 hrs.		1		1, 45	8
W-9-M-61	9"	Core: hollow Rolok of clay or shale; 1/2" of 1:3 sanded gypsum plaster facings on both sides.	See Notes	4 hrs.		1		1, 45	4
W-9-M-62	9"	Cored clay or shale brick; Units in wall thickness: 1; Cells in wall thickness: 1; Minimum % solids: 70; 1/2" of 1:3 sanded gypsum plaster facings on one side.	See Notes	3 hrs.		1		1, 44	3
W-9-M-63	9"	Cored clay or shale brick; Units in wall thickness: 2; Cells in wall thickness: 2; Minimum % solids: 87; 1/2" of 1:3 sanded gypsum plaster facings on both sides.	See Notes	7 hrs.		1		1, 45	7
W-9-M-64	9-10"	Core: cavity wall of clay or shale brick; No facings.	See Notes	5 hrs.		1		1, 45	5
W-9-M-65	9-10"	Core: cavity construction of clay or shale brick; 1/2" of 1:3 sanded gypsum plaster facings on one side.	See Notes	6 hrs.		1		1, 45	6

(Continued)

**TABLE 1.1.4—MASONRY WALLS
8" TO LESS THAN 10" THICK—continued**

ITEM CODE	THICKNESS	CONSTRUCTION DETAILS	PERFORMANCE		REFERENCE NUMBER			NOTES	REC. HOURS
			LOAD	TIME	PRE-BMS-92	BMS-92	POST-BMS-92		
W-9-M-66	9-10"	Core: cavity construction of clay or shale brick; 1/2" of 1:3 sanded gypsum plaster facings on both sides.	See Notes	7 hrs.		1		1, 45	7
W-9-M-67	9 1/4"	Core: clay or shale structural tile; Units in wall thickness: 1; Cells in wall thickness: 2; Minimum % solids in units: 40; 5/8" of 1:3 sanded gypsum plaster facings on both sides.	See Notes	3 hrs.		1		1, 20, 21	3
W-9-M-68	9 1/4"	Core: clay or shale structural tile; Units in wall thickness: 1; Cells in wall thickness: 2; Minimum % solids in units: 43; 5/8" of 1:3 sanded gypsum plaster facings on both sides.	See Notes	3 hrs.		1		1, 20, 21	3
W-9-M-69	9 1/4"	Core: clay or shale structural tile; Facings: sides 1 and 2; see Note 17.	See Notes	3 hrs.		1		1, 2, 5, 10, 18, 20, 21	3
W-9-M-70	9 1/4"	Core: clay or shale structural tile; Facings: sides 1 and 2; see Note 17.	See Notes	4 hrs.		1		1, 2, 5, 13, 18, 20, 21	4
W-9-M-71	9 1/4"	Core: clay or shale structural tile; Facings: sides 1 and 2; see Note 17.	See Notes	3 hrs. 30 min.		1		1, 2, 6, 9, 18, 20, 21	3 1/2
W-9-M-72	9 1/4"	Core: clay or shale structural tile; Facings: sides 1 and 2; see Note 17.	See Notes	4 hrs.		1		1, 2, 6, 10, 18, 20, 21	4
W-9-M-73	9 1/4"	Core: clay or shale structural tile; Facings: sides 1 and 2; see Note 17.	See Notes	4 hrs.		1		1, 2, 6, 12, 18, 20, 21	4
W-9-M-74	9 1/4"	Core: clay or shale structural tile; Facings: sides 1 and 2; see Note 17.	See Notes	5 hrs.		1		1, 2, 6, 16, 18, 20, 21	5
W-9-M-75	8"	Cored concrete masonry; see Notes 2, 19, 26, 34, 40; No facings.	80 psi	1 hr. 30 min.		1		1, 20	1 1/2
W-8-M-76	8"	Cored concrete masonry; see Notes 2, 18, 26, 34, 40; No facings.	80 psi	4 hrs.		1		1, 20	4
W-8-M-77	8"	Cored concrete masonry; see Notes 2, 19, 26, 31, 40; No facings.	80 psi	1 hr. 15 min.		1		1, 20	1 1/4
W-8-M-78	8"	Cored concrete masonry; see Notes 2, 18, 26, 31, 40; No facings.	80 psi	3 hrs.		1		1, 20	3
W-8-M-79	8"	Cored concrete masonry; see Notes 2, 19, 26, 36, 42; No facings.	80 psi	1 hr. 30 min.		1		1, 20	1 1/2
W-8-M-80	8"	Cored concrete masonry; see Notes 2, 18, 26, 36, 41; No facings.	80 psi	3 hrs.		1		1, 20	3

(Continued)

**TABLE 1.1.4—MASONRY WALLS
8" TO LESS THAN 10" THICK—continued**

ITEM CODE	THICKNESS	CONSTRUCTION DETAILS	PERFORMANCE		REFERENCE NUMBER			NOTES	REC. HOURS
			LOAD	TIME	PRE-BMS-92	BMS-92	POST-BMS-92		
W-8-M-81	8"	Cored concrete masonry; see Notes 2, 19, 26, 34, 41; No facings.	80 psi	1 hr.		1		1, 20	1
W-8-M-82	8"	Cored concrete masonry; see Notes 2, 18, 26, 34, 41; No facings.	80 psi	2 hrs. 30 min.		1		1, 20	2½
W-8-M-83	8"	Cored concrete masonry; see Notes 2, 19, 26, 29, 41; No facings.	80 psi	45 min.		1		1, 20	¾
W-8-M-84	8"	Cored concrete masonry; see Notes 2, 18, 26, 29, 41; No facings.	80 psi	2 hrs.		1		1, 20	2
W-8-M-85	8½"	Cored concrete masonry; see Notes 3, 18, 26, 34, 41; Facings: 2¼" brick.	80 psi	4 hrs.		1		1, 20	4
W-8-M-86	8"	Cored concrete masonry; see Notes 3, 18, 26, 34, 41; Facings: 3¾" brick face.	80 psi	5 hrs.		1		1, 20	5
W-8-M-87	8"	Cored concrete masonry; see Notes 2, 19, 26, 30, 43; No facings.	80 psi	12 min.		1		1, 20	1/5
W-8-M-88	8"	Cored concrete masonry; see Notes 2, 18, 26, 30, 43; No facings.	80 psi	12 min.		1		1, 20	1/5
W-8-M-89	8½"	Cored concrete masonry; see Notes 2, 19, 26, 34, 40; Facings: fire side only; see Note 38.	80 psi	2 hrs.		1		1, 20	2
W-8-M-90	8½"	Cored concrete masonry; see Notes 2, 18, 26, 34, 40; Facings: side 1; see Note 38.	80 psi	5 hrs.		1		1, 20	5
W-8-M-91	8½"	Cored concrete masonry; see Notes 2, 19, 26, 31, 40; Facings: fire side only; see Note 38.	80 psi	1 hr. 45 min.		1		1, 20	1¾
W-8-M-92	8½"	Cored concrete masonry; see Notes 2, 18, 26, 31, 40; Facings: one side; see Note 38.	80 psi	4 hrs.		1		1, 20	4
W-8-M-93	8½"	Cored concrete masonry; see Notes 2, 19, 26, 36, 41; Facings: fire side only; see Note 38.	80 psi	2 hrs.		1		1, 20	2
W-8-M-94	8½"	Cored concrete masonry; see Notes 2, 18, 26, 36, 41; Facings: fire side only; see Note 38.	80 psi	4 hrs.		1		1, 20	4
W-8-M-95	8½"	Cored concrete masonry; see Notes 2, 19, 26, 34, 41; Facings: fire side only; see Note 38.	80 psi	1 hr. 30 min.		1		1, 20	1½
W-8-M-96	8½"	Cored concrete masonry; see Notes 2, 18, 26, 34, 41; Facings: one side; see Note 38.	80 psi	3 hrs.				1, 20	3
W-8-M-97	8½"	Cored concrete masonry; see Notes 2, 19, 26, 29, 41; Facings: fire side only; see Note 38.	80 psi	1 hr. 30 min.		1		1, 20	1½

(Continued)

**TABLE 1.1.4—MASONRY WALLS
8" TO LESS THAN 10" THICK—continued**

ITEM CODE	THICKNESS	CONSTRUCTION DETAILS	PERFORMANCE		REFERENCE NUMBER			NOTES	REC. HOURS
			LOAD	TIME	PRE-BMS-92	BMS-92	POST-BMS-92		
W-8-M-98	8½"	Cored concrete masonry; see Notes 2, 18, 26, 29, 41; Facings: one side; see Note 38.	80 psi	2 hrs. 30 min.		1		1, 20	2½
W-8-M-99	8½"	Cored concrete masonry; see Notes 3, 19, 23, 27, 41; No facings.	80 psi	1 hr. 15 min.		1		1, 20	1¼
W-8-M-100	8½"	Cored concrete masonry; see Notes 3, 18, 23, 27, 41; No facings.	80 psi	3 hrs. 30 min.		1		1, 20	3½
W-8-M-101	8½"	Cored concrete masonry; see Notes 3, 18, 26, 34, 41; Facings: 3¾" brick face; one side only; see Note 38.	80 psi	6 hrs.		1		1, 20	6
W-8-M-102	8½"	Cored concrete masonry; see Notes 2, 19, 26, 30, 43; Facings: fire side only; see Note 38.	80 psi	30 min.		1		1, 20	½
W-8-M-103	8½"	Cored concrete masonry; see Notes 2, 18, 26, 30, 43; Facings: one side only; see Note 38.	80 psi	12 min.		1		1, 20	⅕
W-8-M-104	9"	Cored concrete masonry; see Notes 2, 18, 26, 34, 40; Facings: both sides; see Note 38.	80 psi	6 hrs.		1		1, 20	6
W-8-M-105	9"	Cored concrete masonry; see Notes 2, 18, 26, 31, 40; Facings: both sides; see Note 38.	80 psi	5 hrs.		1		1, 20	5
W-8-M-106	9"	Cored concrete masonry; see Notes 2, 18, 26, 36, 41; Facings: both sides of wall; see Note 38.	80 psi	5 hrs.		1		1, 20	5
W-8-M-107	9"	Cored concrete masonry; see Notes 2, 18, 26, 34, 41; Facings: both sides; see Note 38.	80 psi	4 hrs.		1		1, 20	4
W-8-M-108	9"	Cored concrete masonry; see Notes 2, 18, 26, 29, 41; Facings: both sides; see Note 38.	80 psi	3 hrs. 30 min.		1		1, 20	3½
W-8-M-109	9"	Cored concrete masonry; see Notes 3, 19, 23, 27, 40; Facings: fire side only; see Note 38.	80 psi	1 hr. 45 min.		1		1, 20	1¾
W-8-M-110	9"	Cored concrete masonry; see Notes 3, 18, 23, 27, 41; Facings: one side only; see Note 38.	80 psi	4 hrs.		1		1, 20	4
W-8-M-111	9"	Cored concrete masonry; see Notes 3, 18, 26, 34, 41; 2¼" brick face on one side only; see Note 38.	80 psi	5 hrs.		1		1, 20	5
W-8-M-112	9"	Cored concrete masonry; see Notes 2, 18, 26, 30, 43; Facings: both sides; see Note 38.	80 psi	30 min.		1		1, 20	½

(Continued)

**TABLE 1.1.4—MASONRY WALLS
8" TO LESS THAN 10" THICK—continued**

ITEM CODE	THICKNESS	CONSTRUCTION DETAILS	PERFORMANCE		REFERENCE NUMBER			NOTES	REC. HOURS
			LOAD	TIME	PRE-BMS-92	BMS-92	POST-BMS-92		
W-9-M-113	9 1/2"	Cored concrete masonry; see Notes 3, 18, 23, 27, 41; Facings: both sides; see Note 38.	80 psi	5 hrs.		1		1, 20	5
W-8-M-114	8"		200 psi	5 hrs.			43	22	5

For SI: 1 inch = 25.4 mm, 1 pound per square inch = 0.00689 MPa.

Notes:

1. Tested at NBS under ASA Spec. No. 43-1934 (ASTM C 19-53).
2. One unit in wall thickness.
3. Two units in wall thickness.
4. Two or three units in wall thickness.
5. Two cells in wall thickness.
6. Three or four cells in wall thickness.
7. Four or five cells in wall thickness.
8. Five or six cells in wall thickness.
9. Minimum percent of solid materials in units = 40%.
10. Minimum percent of solid materials in units = 43%.
11. Minimum percent of solid materials in units = 46%.
12. Minimum percent of solid materials in units = 48%.
13. Minimum percent of solid materials in units = 49%.
14. Minimum percent of solid materials in units = 45%.
15. Minimum percent of solid materials in units = 51%.
16. Minimum percent of solid materials in units = 53%.
17. Not less than 5/8 inch thickness of 1:3 sanded gypsum plaster.
18. Noncombustible or no members framed into wall.
19. Combustible members framed into wall.
20. Load: 80 psi for gross cross-sectional area of wall.
21. Portland cement-lime mortar.
22. Failure mode thermal.
23. British test.
24. Passed all criteria.
25. Failed by sudden collapse with no preceding signs of impending failure.
26. One cell in wall thickness.
27. Two cells in wall thickness.
28. Three cells in wall thickness.
29. Minimum percent of solid material in concrete units = 52%.
30. Minimum percent of solid material in concrete units = 54%.
31. Minimum percent of solid material in concrete units = 55%.
32. Minimum percent of solid material in concrete units = 57%.
33. Minimum percent of solid material in concrete units = 60%.
34. Minimum percent of solid material in concrete units = 62%.
35. Minimum percent of solid material in concrete units = 65%.
36. Minimum percent of solid material in concrete units = 70%.
37. Minimum percent of solid material in concrete units = 76%.
38. Not less than 1/2 inch of 1:3 sanded gypsum plaster.
39. Three units in wall thickness.
40. Concrete units made with expanded slag or pumice aggregates.
41. Concrete units made with expanded burned clay or shale, crushed limestone, air cooled slag or cinders.
42. Concrete units made with calcareous sand and gravel. Coarse aggregate, 60 percent or more calcite and dolomite.
43. Concrete units made with siliceous sand and gravel. Ninety percent or more quartz, chert and dolomite.
44. Load: 120 psi for gross cross-sectional area of wall.
45. Load: 160 psi for gross cross-sectional area of wall.

**FIGURE 1.1.5—MASONRY WALLS
10" TO LESS THAN 12" THICK**

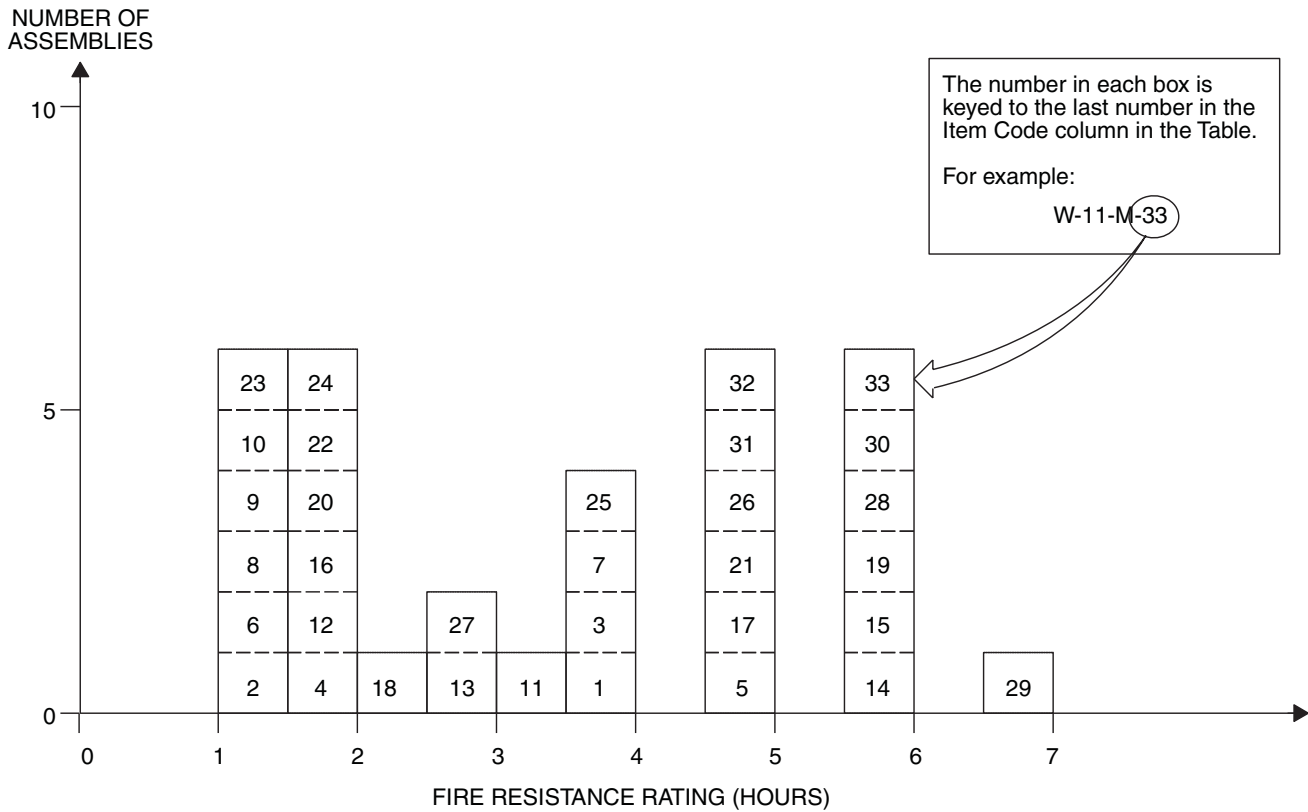

**TABLE 1.1.5—MASONRY WALLS
10" TO LESS THAN 12" THICK**

ITEM CODE	THICKNESS	CONSTRUCTION DETAILS	PERFORMANCE		REFERENCE NUMBER			NOTES	REC. HOURS
			LOAD	TIME	PRE-BMS-92	BMS-92	POST-BMS-92		
W-10-M-1	10"	Core: two 3 ³ / ₄ ", 40% solid clay or shale structural tiles with 2" air space between; Facings: 3/4" portland cement plaster on stucco on both sides.	80 psi	4 hrs.		1		1, 20	4
W-10-M-2	10"	Core: cored concrete masonry, 2" air cavity; see Notes 3, 19, 27, 34, 40; No facings.	80 psi	1 hr. 30 min.		1		1, 20	1 1/2
W-10-M-3	10"	Cored concrete masonry; see Notes 3, 18, 27, 34, 40; No facings.	80 psi	4 hrs.		1		1, 20	4
W-10-M-4	10"	Cored concrete masonry; see Notes 2, 19, 26, 34, 40; No facings.	80 psi	2 hrs.		1		1, 20	2
W-10-M-5	10"	Cored concrete masonry; see Notes 2, 18, 26, 33, 40; No facings.	80 psi	5 hrs.		1		1, 20	5
W-10-M-6	10"	Cored concrete masonry; see Notes 2, 19, 26, 33, 41; No facings.	80 psi	1 hr. 30 min.		1		1, 20	1 1/2
W-10-M-7	10"	Cored concrete masonry; see Notes 2, 18, 26, 33, 41; No facings.	80 psi	4 hrs.		1		1, 20	4

(Continued)

**TABLE 1.1.5—MASONRY WALLS
10" TO LESS THAN 12" THICK—continued**

ITEM CODE	THICKNESS	CONSTRUCTION DETAILS	PERFORMANCE		REFERENCE NUMBER			NOTES	REC. HOURS
			LOAD	TIME	PRE-BMS-92	BMS-92	POST-BMS-92		
W-10-M-8	10"	Cored concrete masonry (cavity type 2" air space); see Notes 3, 19, 27, 34, 42; No facings.	80 psi	1 hr. 15 min.		1		1, 20	1 ¹ / ₄
W-10-M-9	10"	Cored concrete masonry (cavity type 2" air space); see Notes 3, 18, 27, 34, 42; No facings.	80 psi	1 hr. 15 min.		1		1, 20	1 ¹ / ₄
W-10-M-10	10"	Cored concrete masonry (cavity type 2" air space); see Notes 3, 19, 27, 34, 41; No facings.	80 psi	1 hr. 15 min.		1		1, 20	1 ¹ / ₄
W-10-M-11	10"	Cored concrete masonry (cavity type 2" air space); see Notes 3, 18, 27, 34, 41; No facings.	80 psi	3 hrs. 30 min.		1		1, 20	3 ¹ / ₂
W-10-M-12	10"	9" thick concrete block (11 ³ / ₄ " × 9" × 4 ¹ / ₄ ") with two 2" thick voids included; ³ / ₈ " P.C. plaster ¹ / ₈ " neat gypsum.	N/A	1 hr. 53 min.			7	23, 44	1 ³ / ₄
W-10-M-13	10"	Holly clay tile block wall - 8 ¹ / ₂ " block with two 3" voids in each 8 ¹ / ₂ " section; ³ / ₄ " gypsum plaster - each face.	N/A	2 hrs. 42 min.			7	23, 25	2 ¹ / ₂
W-10-M-14	10"	Two layers 4 ¹ / ₄ " brick with 1 ¹ / ₂ " air space; No ties sand cement mortar. (Fletton brick - 1910 psi).	N/A	6 hrs.			7	23, 24	6
W-10-M-15	10"	Two layers 4 ¹ / ₄ " thick Fletton brick (1910 psi); 1 ¹ / ₂ " air space; Ties: 18" o.c. vertical; 3' o.c. horizontal.	N/A	6 hrs.			7	23, 24	6
W-10-M-16	10 ¹ / ₂ "	Cored concrete masonry; 2" air cavity; see Notes 3, 19, 27, 34, 40; Facings: fire side only; see Note 38.	80 psi	2 hrs.		1		1, 20	2
W-10-M-17	10 ¹ / ₂ "	Cored concrete masonry; see Notes 3, 18, 27, 34, 40; Facings: side 1 only; see Note 38.	80 psi	5 hrs.		1		1, 20	5
W-10-M-18	10 ¹ / ₂ "	Cored concrete masonry; see Notes 2, 19, 26, 33, 40; Facings: fire side only; see Note 38.	80 psi	2 hrs. 30 min.		1		1, 20	2 ¹ / ₂
W-10-M-19	10 ¹ / ₂ "	Cored concrete masonry; see Notes 2, 18, 26, 33, 40; Facings: one side; see Note 38.	80 psi	6 hrs.		1		1, 20	6
W-10-M-20	10 ¹ / ₂ "	Cored concrete masonry; see Notes 2, 19, 26, 33, 41; Facings: fire side of wall only; see Note 38.	80 psi	2 hrs.		1		1, 20	2
W-10-M-21	10 ¹ / ₂ "	Cored concrete masonry; see Notes 2, 18, 26, 33, 41; Facings: one side only; see Note 38.	80 psi	5 hrs.		1		1, 20	5
W-10-M-22	10 ¹ / ₂ "	Cored concrete masonry (cavity type 2" air space); see Notes 3, 19, 27, 34, 42; Facings: fire side only; see Note 38.	80 psi	1 hr. 45 min.		1		1, 20	1 ³ / ₄

(Continued)

**TABLE 1.1.5—MASONRY WALLS
10' TO LESS THAN 12" THICK—continued**

ITEM CODE	THICKNESS	CONSTRUCTION DETAILS	PERFORMANCE		REFERENCE NUMBER			NOTES	REC. HOURS
			LOAD	TIME	PRE-BMS-92	BMS-92	POST-BMS-92		
W-10-M-23	10 ¹ / ₂ "	Cored concrete masonry (cavity type 2" air space); see Notes 3, 18, 27, 34, 42; Facings: one side only; see Note 38.	80 psi	1 hr. 15 min.		1		1, 20	1 ¹ / ₄
W-10-M-24	10 ¹ / ₂ "	Cored concrete masonry (cavity type 2" air space); see Notes 3, 19, 27, 34, 41; Facings: fire side only; see Note 38.	80 psi	2 hrs.		1		1, 20	2
W-10-M-25	10 ¹ / ₂ "	Cored concrete masonry (cavity type 2" air space); see Notes 3, 18, 27, 34, 41; Facings: one side only; see Note 38.	80 psi	4 hrs.		1		1, 20	4
W-10-M-26	10 ⁵ / ₈ "	Core: 8", 40% solid tile plus 2" furring tile; ⁵ / ₈ " sanded gypsum plaster between tile types; Facings: both sides ³ / ₄ " portland cement plaster or stucco.	80 psi	5 hrs.		1		1, 20	5
W-10-M-27	10 ⁵ / ₈ "	Core: 8", 40% solid tile plus 2" furring tile; ⁵ / ₈ " sanded gypsum plaster between tile types; Facings: one side ³ / ₄ " portland cement plaster or stucco.	80 psi	3 hrs. 30 min.		1		1, 20	3 ¹ / ₂
W-11-M-28	11"	Cored concrete masonry; see Notes 3, 18, 27, 34, 40; Facings: both sides; see Note 38.	80 psi	6 hrs.		1		1, 20	6
W-11-M-29	11"	Cored concrete masonry; see Notes 2, 18, 26, 33, 40; Facings: both sides; see Note 38.	80 psi	7 hrs.		1		1, 20	7
W-11-M-30	11"	Cored concrete masonry; see Notes 2, 18, 26, 33, 41; Facings: both sides of wall; see Note 38.	80 psi	6 hrs.		1		1, 20	6
W-11-M-31	11"	Cored concrete masonry (cavity type 2" air space); see Notes 3, 18, 27, 34, 42; Facings: both sides; see Note 38.	80 psi	5 hrs.		1		1, 20	5
W-11-M-32	11"	Cored concrete masonry (cavity type 2" air space); see Notes 3, 18, 27, 34, 41; Facings: both sides; see Note 38.	80 psi	5 hrs.		1		1, 20	5

(Continued)

**TABLE 1.1.5—MASONRY WALLS
10" TO LESS THAN 12" THICK—continued**

ITEM CODE	THICKNESS	CONSTRUCTION DETAILS	PERFORMANCE		REFERENCE NUMBER			NOTES	REC. HOURS
			LOAD	TIME	PRE-BMS-92	BMS-92	POST-BMS-92		
W-11-M-33	11"	Two layers brick (4 1/2" Fletton, 2,428 psi) 2" air space; galvanized ties; 18" o.c. - horizontal; 3' o.c. - vertical.	3 tons/ft.	6 hrs.			7	23, 24	6

For SI: 1 inch = 25.4 mm, 1 pound per square inch = 0.00689 MPa.

Notes:

1. Tested at NBS - ASA Spec. No. A2-1934.
2. One unit in wall thickness.
3. Two units in wall thickness.
4. Two or three units in wall thickness.
5. Two cells in wall thickness.
6. Three or four cells in wall thickness.
7. Four or five cells in wall thickness.
8. Five or six cells in wall thickness.
9. Minimum percent of solid materials in units = 40%.
10. Minimum percent of solid materials in units = 43%.
11. Minimum percent of solid materials in units = 46%.
12. Minimum percent of solid materials in units = 48%.
13. Minimum percent of solid materials in units = 49%.
14. Minimum percent of solid materials in units = 45%.
15. Minimum percent of solid materials in units = 51%.
16. Minimum percent of solid materials in units = 53%.
17. Not less than 3/8 inch thickness of 1:3 sanded gypsum plaster.
18. Noncombustible or no members framed into wall.
19. Combustible members framed into wall.
20. Load: 80 psi for gross cross sectional area of wall.
21. Portland cement-lime mortar.
22. Failure mode - thermal.
23. British test.
24. Passed all criteria.
25. Failed by sudden collapse with no preceding signs of impending failure.
26. One cell in wall thickness.
27. Two cells in wall thickness.
28. Three cells in wall thickness.
29. Minimum percent of solid material in concrete units = 52%.
30. Minimum percent of solid material in concrete units = 54%.
31. Minimum percent of solid material in concrete units = 55%.
32. Minimum percent of solid material in concrete units = 57%.
33. Minimum percent of solid material in concrete units = 60%.
34. Minimum percent of solid material in concrete units = 62%.
35. Minimum percent of solid material in concrete units = 65%.
36. Minimum percent of solid material in concrete units = 70%.
37. Minimum percent of solid material in concrete units = 76%.
38. Not less than 1/2 inch of 1:3 sanded gypsum plaster.
39. Three units in wall thickness.
40. Concrete units made with expanded slag or pumice aggregates.
41. Concrete units made with expanded burned clay or shale, crushed limestone, air cooled slag or cinders.
42. Concrete units made with calcareous sand and gravel. Coarse aggregate, 60 percent or more calcite and dolomite.

**FIGURE 1.1.6—MASONRY WALLS
12" TO LESS THAN 14" THICK**

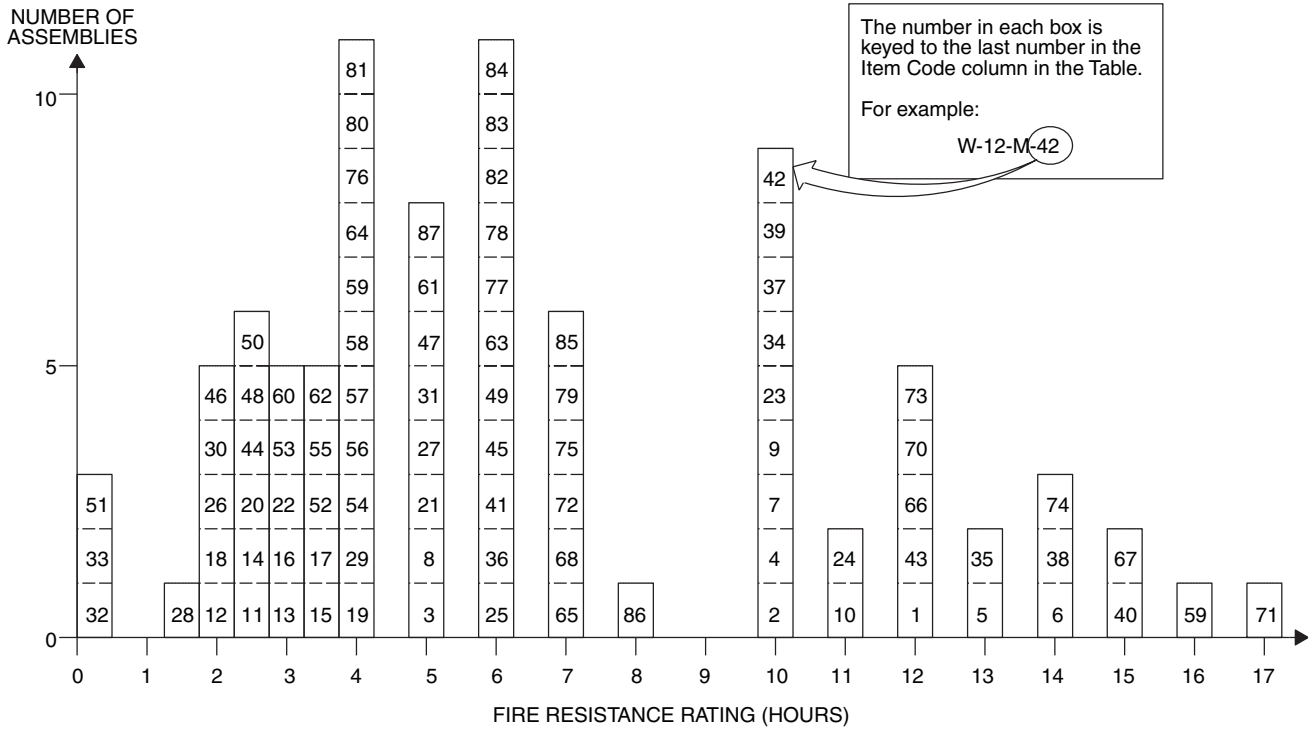

**TABLE 1.1.6—MASONRY WALLS
12" TO LESS THAN 14" THICK**

ITEM CODE	THICKNESS	CONSTRUCTION DETAILS	PERFORMANCE		REFERENCE NUMBER			NOTES	REC. HOURS
			LOAD	TIME	PRE-BMS-92	BMS-92	POST-BMS-92		
W-12-M-1	12"	Core: solid clay or shale brick; No facings.	N/A	12 hrs.		1		1	12
W-12-M-2	12"	Core: solid clay or shale brick; No facings.	160 psi	10 hrs.		1		1, 44	10
W-12-M-3	12"	Core: hollow Rolok of clay or shale; No facings.	160 psi	5 hrs.		1		1, 44	5
W-12-M-4	12"	Core: hollow Rolok Bak of clay or shale; No facings.	160 psi	10 hrs.		1		1, 44	10
W-12-M-5	12"	Core: concrete brick; No facings.	160 psi	13 hrs.		1		1, 44	13
W-12-M-6	12"	Core: sand-lime brick; No facings.	N/A	14 hrs.		1		1	14
W-12-M-7	12"	Core: sand-lime brick; No facings.	160 psi	10 hrs.		1		1, 44	10
W-12-M-8	12"	Cored clay or shale brick; Units in wall thickness: 1; Cells in wall thickness: 2; Minimum % solids: 70; No facings.	120 psi	5 hrs.		1		1, 45	5
W-12-M-9	12"	Cored clay or shale brick; Units in wall thickness: 3; Cells in wall thickness: 3; Minimum % solids: 87; No facings.	160 psi	10 hrs.		1		1, 44	10

(Continued)

**TABLE 1.1.6—MASONRY WALLS
12" TO LESS THAN 14" THICK—continued**

ITEM CODE	THICKNESS	CONSTRUCTION DETAILS	PERFORMANCE		REFERENCE NUMBER			NOTES	REC. HOURS
			LOAD	TIME	PRE-BMS-92	BMS-92	POST-BMS-92		
W-12-M-10	12"	Cored clay or shale brick; Units in wall thickness: 3; Cells in wall thickness: 3; Minimum % solids: 87; No facings.	N/A	11 hrs.		1		1	11
W-12-M-11	12"	Core: clay or shale structural tile; see Notes 2, 6, 9, 18; No facings.	80 psi	2 hrs.		1		1, 20	2½
W-12-M-12	12"	Core: clay or shale structural tile; see Notes 2, 4, 9, 19; No facings.	80 psi	2 hrs.		1		1, 20	2
W-12-M-13	12"	Core: clay or shale structural tile; see Notes 2, 6, 14, 19; No facings.	80 psi	3 hrs.		1		1, 20	3
W-12-M-14	12"	Core: clay or shale structural tile; see Notes 2, 6, 14, 18; No facings.	80 psi	2 hrs. 30 min.		1		1, 20	2½
W-12-M-15	12"	Core: clay or shale structural tile; see Notes 2, 4, 13, 18; No facings.	80 psi	3 hrs. 30 min.		1		1, 20	3½
W-12-M-16	12"	Core: clay or shale structural tile; see Notes 2, 4, 13, 19; No facings.	80 psi	3 hrs.		1		1, 20	3
W-12-M-17	12"	Core: clay or shale structural tile; see Notes 3, 6, 9, 18; No facings.	80 psi	3 hrs. 30 min.		1		1, 20	3½
W-12-M-18	12"	Core: clay or shale structural tile; see Notes 3, 6, 9, 19; No facings.	80 psi	2 hrs.		1		1, 20	2
W-12-M-19	12"	Core: clay or shale structural tile; see Notes 3, 6, 14, 18; No facings.	80 psi	4 hrs.		1		1, 20	4
W-12-M-20	12"	Core: clay or shale structural tile; see Notes 3, 6, 14, 19; No facings.	80 psi	2 hrs. 30 min.		1		1, 20	2½
W-12-M-21	12"	Core: clay or shale structural tile; see Notes 3, 6, 16, 18; No facings.	80 psi	5 hrs.		1		1, 20	5
W-12-M-22	12"	Core: clay or shale structural tile; see Notes 3, 6, 16, 19; No facings.	80 psi	3 hrs.		1		1, 20	3
W-12-M-23	12"	Core: 8", 70% solid clay or shale structural tile; 4" brick facings on one side.	80 psi	10 hrs.		1		1, 20	10
W-12-M-24	12"	Core: 8", 70% solid clay or shale structural tile; 4" brick facings on one side.	N/A	11 hrs.		1		1	11
W-12-M-25	12"	Core: 8", 40% solid clay or shale structural tile; 4" brick facings on one side.	80 psi	6 hrs.		1		1, 20	6
W-12-M-26	12"	Cored concrete masonry; see Notes 1, 9, 15, 16, 20; No facings.	80 psi	2 hrs.		1		1, 20	2
W-12-M-27	12"	Cored concrete masonry; see Notes 2, 18, 26, 34, 41; No facings.	80 psi	5 hrs.		1		1, 20	5
W-12-M-28	12"	Cored concrete masonry; see Notes 2, 19, 26, 31, 41; No facings.	80 psi	1 hr. 30 min.		1		1, 20	1½
W-12-M-29	12"	Cored concrete masonry; see Notes 2, 18, 26, 31, 41; No facings.	80 psi	4 hrs.		1		1, 20	4

(Continued)

**TABLE 1.1.6—MASONRY WALLS
12" TO LESS THAN 14" THICK—continued**

ITEM CODE	THICKNESS	CONSTRUCTION DETAILS	PERFORMANCE		REFERENCE NUMBER			NOTES	REC. HOURS
			LOAD	TIME	PRE-BMS-92	BMS-92	POST-BMS-92		
W-12-M-30	12"	Cored concrete masonry; see Notes 3, 19, 27, 31, 43; No facings.	80 psi	2 hrs.		1		1, 20	2
W-12-M-31	12"	Cored concrete masonry; see Notes 3, 18, 27, 31, 43; No facings.	80 psi	5 hrs.		1		1, 20	5
W-12-M-32	12"	Cored concrete masonry; see Notes 2, 19, 26, 32, 43; No facings.	80 psi	25 min.		1		1, 20	1/3
W-12-M-33	12"	Cored concrete masonry; see Notes 2, 18, 26, 32, 43; No facings.	80 psi	25 min.		1		1, 20	1/3
W-12-M-34	12 1/2"	Core: solid clay or shale brick; 1/2" of 1:3 sanded gypsum plaster facings on one side.	160 psi	10 hrs.		1		1, 44	10
W-12-M-35	12 1/2"	Core: solid clay or shale brick; 1/2" of 1:3 sanded gypsum plaster facings on one side.	N/A	13 hrs.		1		1	13
W-12-M-36	12 1/2"	Core: hollow Rolok of clay or shale; 1/2" of 1:3 sanded gypsum plaster facings on one side.	160 psi	6 hrs.		1		1, 44	6
W-12-M-37	12 1/2"	Core: hollow Rolok Bak of clay or shale; 1/2" of 1:3 sanded gypsum plaster facings on one side.	160 psi	10 hrs.		1		1, 44	10
W-12-M-38	12 1/2"	Core: concrete; 1/2" of 1:3 sanded gypsum plaster facings on one side.	160 psi	14 hrs.		1		1, 44	14
W-12-M-39	12 1/2"	Core: sand-lime brick; 1/2" of 1:3 sanded gypsum plaster facings on one side.	160 psi	10 hrs.		1		1, 44	10
W-12-M-40	12 1/2"	Core: sand-lime brick; 1/2" of 1:3 sanded gypsum plaster facings on one side.	N/A	15 hrs.		1		1	15
W-12-M-41	12 1/2"	Cored clay or shale brick; Units in wall thickness: 1; Cells in wall thickness: 2; Minimum % solids: 70; 1/2" of 1:3 sanded gypsum plaster facings on one side.	120 psi	6 hrs.		1		1, 45	6
W-12-M-42	12 1/2"	Cored clay or shale brick; Units in wall thickness: 3; Cells in wall thickness: 3; Minimum % solids: 87; 1/2" of 1:3 sanded gypsum plaster facings on one side.	160 psi	10 hrs.		1		1, 44	10
W-12-M-43	12 1/2"	Cored clay or shale brick; Units in wall thickness: 3; Cells in wall thickness: 3; Minimum % solids: 87; 1/2" of 1:3 sanded gypsum plaster facings on one side.	N/A	12 hrs.		1		1	12

(Continued)

**TABLE 1.1.6—MASONRY WALLS
12" TO LESS THAN 14" THICK—continued**

ITEM CODE	THICKNESS	CONSTRUCTION DETAILS	PERFORMANCE		REFERENCE NUMBER			NOTES	REC. HOURS
			LOAD	TIME	PRE-BMS-92	BMS-92	POST-BMS-92		
W-12-M-44	12½"	Cored concrete masonry; see Notes 2, 19, 26, 34, 41; Facings: fire side only; see Note 38.	80 psi	2 hrs. 30 min.		1		1, 20	2½
W-12-M-45	12½"	Cored concrete masonry; see Notes 2, 18, 26, 34, 39, 41; Facings: one side only; see Note 38.	80 psi	6 hrs.		1		1, 20	6
W-12-M-46	12½"	Cored concrete masonry; see Notes 2, 19, 26, 31, 41; Facings: fire side only; see Note 38.	80 psi	2 hrs.		1		1, 20	2
W-12-M-47	12½"	Cored concrete masonry; see Notes 2, 18, 26, 31, 41; Facings: one side of wall only; see Note 38.	80 psi	5 hrs.		1		1, 20	5
W-12-M-48	12½"	Cored concrete masonry; see Notes 3, 19, 27, 31, 43; Facings: fire side only; see Note 38.	80 psi	2 hrs. 30 min.		1		1, 20	2½
W-12-M-49	12½"	Cored concrete masonry; see Notes 3, 18, 27, 31, 43; Facings: one side only; see Note 38.	80 psi	6 hrs.		1		1, 20	6
W-12-M-50	12½"	Cored concrete masonry; see Notes 2, 19, 26, 32, 43; Facings: fire side only; see Note 38.	80 psi	2 hrs. 30 min.		1		1, 20	2½
W-12-M-51	12½"	Cored concrete masonry; see Notes 2, 18, 26, 32, 43; Facings: one side only; see Note 38.	80 psi	25 min.		1		1, 20	1/3
W-12-M-52	12 ⁵ / ₈ "	Clay or shale structural tile; see Notes 2, 6, 9, 18; Facings: side 1, see Note 17; side 2, none.	80 psi	3 hrs. 30 min.		1		1, 20	3½
W-12-M-53	12 ⁵ / ₈ "	Clay or shale structural tile; see Notes 2, 6, 9, 19; Facings: fire side only; see Note 17.	80 psi	3 hrs.		1		1, 20	3
W-12-M-54	12 ⁵ / ₈ "	Clay or shale structural tile; see Notes 2, 6, 14, 19; Facings: side 1, see Note 17; side 2, none.	80 psi	4 hrs.		1		1, 20	4
W-12-M-55	12 ⁵ / ₈ "	Clay or shale structural tile; see Notes 2, 6, 14, 18; Facings: exposed side only; see note 17.	80 psi	3 hrs. 30 min.		1		1, 20	3½
W-12-M-56	12 ⁵ / ₈ "	Clay or shale structural tile; see Notes 2, 4, 13, 18; Facings: side 1, see Note 17; side 2, none.	80 psi	4 hrs.		1		1, 20	4
W-12-M-57	12 ⁵ / ₈ "	Clay or shale structural tile; see Notes 1, 4, 13, 19; Facings: fire side only; see Note 17.	80 psi	4 hrs.		1		1, 20	4
W-12-M-58	12 ⁵ / ₈ "	Clay or shale structural tile; see Notes 3, 6, 9, 18; Facings: side 1, see Note 17; side 2, none.	80 psi	4 hrs.		1		1, 20	4
W-12-M-59	12 ⁵ / ₈ "	Clay or shale structural tile; see Notes 3, 6, 9, 19; Facings: fire side only; see Note 17.	80 psi	3 hrs.		1		1, 20	3

(Continued)

**TABLE 1.1.6—MASONRY WALLS
12" TO LESS THAN 14" THICK—continued**

ITEM CODE	THICKNESS	CONSTRUCTION DETAILS	PERFORMANCE		REFERENCE NUMBER			NOTES	REC. HOURS
			LOAD	TIME	PRE-BMS-92	BMS-92	POST-BMS-92		
W-12-M-60	12 ⁵ / ₈ "	Clay or shale structural tile; see Notes 3, 6, 14, 18; Facings: side 1, see Note 17; side 2, none.	80 psi	5 hrs.		1		1, 20	5
W-12-M-61	12 ⁵ / ₈ "	Clay or shale structural tile; see Notes 3, 6, 14, 19; Facings: fire side only; see Note 17.	80 psi	3 hrs. 30 min.		1		1, 20	3 ¹ / ₂
W-12-M-62	12 ⁵ / ₈ "	Clay or shale structural tile; see Notes 3, 6, 16, 18; Facings: side 1, see Note 17; side 2, none.	80 psi	6 hrs.		1		1, 20	6
W-12-M-63	12 ⁵ / ₈ "	Clay or shale structural tile; see Notes 3, 6, 16, 19; Facings: fire side only; see Note 17.	80 psi	4 hrs.		1		1, 20	4
W-12-M-64	12 ⁵ / ₈ "	Core: 8", 40% solid clay or shale structural tile; Facings: 4" brick plus ⁵ / ₈ " of 1:3 sanded gypsum plaster on one side.	80 psi	7 hrs.		1		1, 20	7
W-13-M-65	13"	Core: solid clay or shale brick; ¹ / ₂ " of 1:3 sanded gypsum plaster facings on both sides.	160 psi	12 hrs.		1		1, 44	12
W-13-M-66	13"	Core: solid clay or shale brick; ¹ / ₂ " of 1:3 sanded gypsum plaster facings on both sides.	N/A	15 hrs.		1		1, 20	15
W-13-M-67	13"	Core: solid clay or shale brick; ¹ / ₂ " of 1:3 sanded gypsum plaster facings on both sides.	N/A	15 hrs.		1		1	15
W-13-M-68	13"	Core: hollow Rolok of clay or shale; ¹ / ₂ " of 1:3 sanded gypsum plaster facings on both sides.	80 psi	7 hrs.		1		1, 20	7
W-13-M-69	13"	Core: concrete brick; ¹ / ₂ " of 1:3 sanded gypsum plaster facings on both sides.	160 psi	16 hrs.		1		1, 44	16
W-13-M-70	13"	Core: sand-lime brick; ¹ / ₂ " of 1:3 sanded gypsum plaster facings on both sides.	160 psi	12 hrs.		1		1, 44	12
W-13-M-71	13"	Core: sand-lime brick; ¹ / ₂ " of 1:3 sanded gypsum plaster facings on both sides.	N/A	17 hrs.		1		1	17
W-13-M-72	13"	Cored clay or shale brick; Units in wall thickness: 1; Cells in wall thickness: 2; Minimum % solids: 70; ¹ / ₂ " of 1:3 sanded gypsum plaster facings on both sides.	120 psi	7 hrs.		1		1, 45	7
W-13-M-73	13"	Cored clay or shale brick; Units in wall thickness: 3; Cells in wall thickness: 3; Minimum % solids: 87; ¹ / ₂ " of 1:3 sanded gypsum plaster facings on both sides.	160 psi	12 hrs.		1		1, 44	12
W-13-M-74	13"	Cored clay or shale brick; Units in wall thickness: 3; Cells in wall thickness: 2; Minimum % solids: 87; ¹ / ₂ " of 1:3 sanded gypsum plaster facings on both sides.	N/A	14 hrs.		1		1	14

(Continued)

**TABLE 1.1.6—MASONRY WALLS
12" TO LESS THAN 14" THICK—continued**

ITEM CODE	THICKNESS	CONSTRUCTION DETAILS	PERFORMANCE		REFERENCE NUMBER			NOTES	REC. HOURS
			LOAD	TIME	PRE-BMS-92	BMS-92	POST-BMS-92		
W-13-M-75	13"	Cored concrete masonry; see Notes 18, 23, 28, 39, 41; No facings.	80 psi	7 hrs.		1		1, 20	7
W-13-M-76	13"	Cored concrete masonry; see Notes 19, 23, 28, 39, 41; No facings.	80 psi	4 hrs.		1		1, 20	4
W-13-M-77	13"	Cored concrete masonry; see Notes 3, 18, 27, 31, 43; Facings: both sides; see Note 38.	80 psi	6 hrs.		1		1, 20	6
W-13-M-78	13"	Cored concrete masonry; see Notes 2, 18, 26, 31, 41; Facings: both sides; see Note 38.	80 psi	6 hrs.		1		1, 20	6
W-13-M-79	13"	Cored concrete masonry; see Notes 2, 18, 26, 34, 41; Facings: both sides of wall; see Note 38.	80 psi	7 hrs.		1		1, 20	7
W-13-M-80	13 ¹ / ₄ "	Core: clay or shale structural tile; see Notes 2, 6, 9, 18; Facings: both sides; see Note 17.	80 psi	4 hrs.		1		1, 20	4
W-13-M-81	13 ¹ / ₄ "	Core: clay or shale structural tile; see Notes 2, 6, 14, 19; Facings: both sides; see Note 17.	80 psi	4 hrs.		1		1, 20	4
W-13-M-82	13 ¹ / ₄ "	Core: clay or shale structural tile; see Notes 2, 4, 13, 18; Facings: both sides; see Note 17.	80 psi	6 hrs.		1		1, 20	6
W-13-M-83	13 ¹ / ₄ "	Core: clay or shale structural tile; see Notes 3, 6, 9, 18; Facings: both sides; see Note 17.	80 psi	6 hrs.		1		1, 20	6
W-13-M-84	13 ¹ / ₄ "	Core: clay or shale structural tile; see Notes 3, 6, 14, 18; Facings: both sides; see Note 17.	80 psi	6 hrs.		1		1, 20	6
W-13-M-85	13 ¹ / ₄ "	Core: clay or shale structural tile; see Notes 3, 6, 16, 18; Facings: both sides; see Note 17.	80 psi	7 hrs.		1		1, 20	7
W-13-M-86	13 ¹ / ₂ "	Cored concrete masonry; see Notes 18, 23, 28, 39, 41; Facings: one side only; see Note 38.	80 psi	8 hrs.		1		1, 20	8

(Continued)

**TABLE 1.1.6—MASONRY WALLS
12" TO LESS THAN 14" THICK—continued**

ITEM CODE	THICKNESS	CONSTRUCTION DETAILS	PERFORMANCE		REFERENCE NUMBER			NOTES	REC. HOURS
			LOAD	TIME	PRE-BMS-92	BMS-92	POST-BMS-92		
W-13-M-87	13 ¹ / ₂ "	Cored concrete masonry; see Notes 19, 23, 28, 39, 41; Facings: fire side only; see Note 38.	80 psi	5 hrs.		1		1, 20	5

For SI: 1 inch = 25.4 mm, 1 pound per square inch = 0.00689 MPa.

Notes:

1. Tested at NBS - ASA Spec. No. A2-1934.
2. One unit in wall thickness.
3. Two units in wall thickness.
4. Two or three units in wall thickness.
5. Two cells in wall thickness.
6. Three or four cells in wall thickness.
7. Four or five cells in wall thickness.
8. Five or six cells in wall thickness.
9. Minimum percent of solid materials in units = 40%.
10. Minimum percent of solid materials in units = 43%.
11. Minimum percent of solid materials in units = 46%.
12. Minimum percent of solid materials in units = 48%.
13. Minimum percent of solid materials in units = 49%.
14. Minimum percent of solid materials in units = 45%.
15. Minimum percent of solid materials in units = 51%.
16. Minimum percent of solid materials in units = 53%.
17. Not less than 5/8 inch thickness of 1:3 sanded gypsum plaster.
18. Noncombustible or no members framed into wall.
19. Combustible members framed into wall.
20. Load: 80 psi for gross area.
21. Portland cement-lime mortar.
22. Failure mode-thermal.
23. British test.
24. Passed all criteria.
25. Failed by sudden collapse with no preceding signs of impending failure.
26. One cell in wall thickness.
27. Two cells in wall thickness.
28. Three cells in wall thickness.
29. Minimum percent of solid material in concrete units = 52%.
30. Minimum percent of solid material in concrete units = 54%.
31. Minimum percent of solid material in concrete units = 55%.
32. Minimum percent of solid material in concrete units = 57%.
33. Minimum percent of solid material in concrete units = 60%.
34. Minimum percent of solid material in concrete units = 62%.
35. Minimum percent of solid material in concrete units = 65%.
36. Minimum percent of solid material in concrete units = 70%.
37. Minimum percent of solid material in concrete units = 76%.
38. Not less than 1/2 inch of 1:3 sanded gypsum plaster.
39. Three units in wall thickness.
40. Concrete units made with expanded slag or pumice aggregates.
41. Concrete units made with expanded burned clay or shale, crushed limestone, air cooled slag or cinders.
42. Concrete units made with calcareous sand and gravel. Coarse aggregate, 60 percent or more calcite and dolomite.
43. Concrete units made with siliceous sand and gravel. Ninety percent or more quartz, chert or flint.
44. Load: 160 psi of gross wall cross sectional area.
45. Load: 120 psi of gross wall cross sectional area.

**FIGURE 1.1.7—MASONRY WALLS
14" OR MORE THICK**

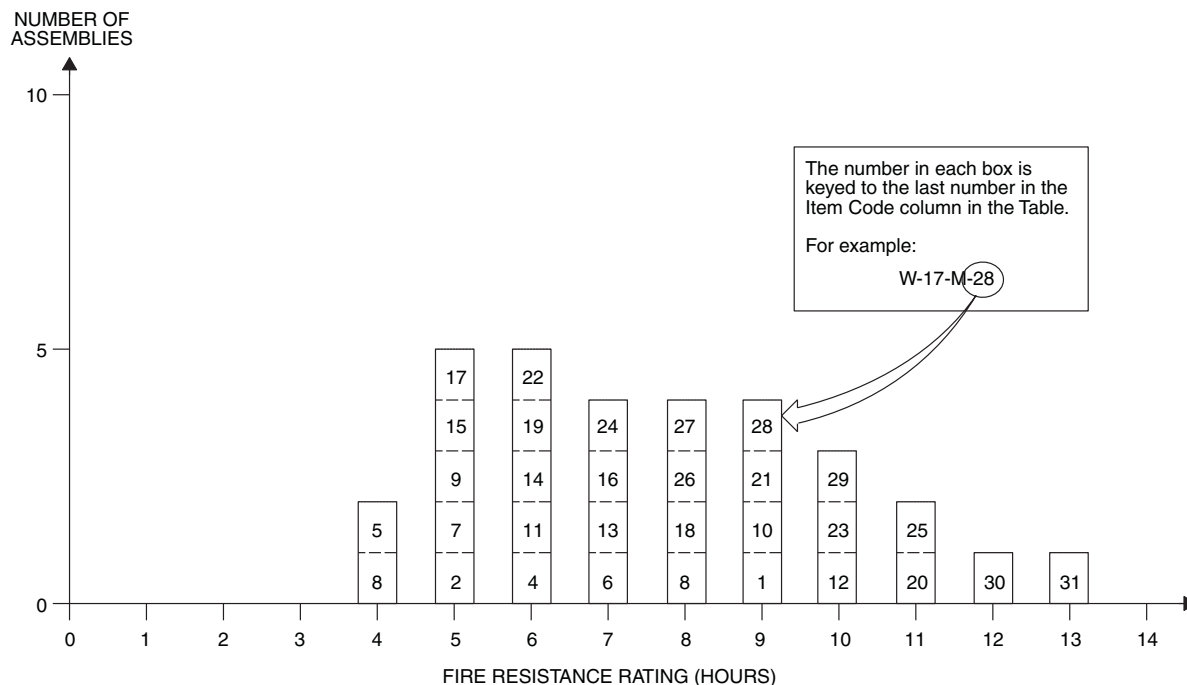

**TABLE 1.1.7—MASONRY WALLS
14" OR MORE THICK**

ITEM CODE	THICKNESS	CONSTRUCTION DETAILS	PERFORMANCE		REFERENCE NUMBER			NOTES	REC. HOURS
			LOAD	TIME	PRE-BMS-92	BMS-92	POST-BMS-92		
W-14-M-1	14"	Core: cored masonry; see Notes 18, 28, 33, 39, 41; Facings: both sides; see Note 38.	80 psi	9 hrs.		1		1, 20	9
W-16-M-2	16"	Core: clay or shale structural tile; see Notes 4, 7, 9, 19; No facings.	80 psi	5 hrs.		1		1, 20	5
W-16-M-3	16"	Core: clay or shale structural tile; see Notes 4, 7, 9, 19; No facings.	80 psi	4 hrs.		1		1, 20	4
W-16-M-4	16"	Core: clay or shale structural tile; see Notes 4, 7, 10, 18; No facings.	80 psi	6 hrs.		1		1, 20	6
W-16-M-5	16"	Core: clay or shale structural tile; see Notes 4, 7, 10, 19; No facings.	80 psi	4 hrs.		1		1, 20	4
W-16-M-6	16"	Core: clay or shale structural tile; see Notes 4, 7, 11, 18; No facings.	80 psi	7 hrs.		1		1, 20	7
W-16-M-7	16"	Core: clay or shale structural tile; see Notes 4, 7, 11, 19; No facings.	80 psi	5 hrs.		1		1, 20	5
W-16-M-8	16"	Core: clay or shale structural tile; see Notes 4, 8, 13, 18; No facings.	80 psi	8 hrs.		1		1, 20	8
W-16-M-9	16"	Core: clay or shale structural tile; see Notes 4, 8, 13, 19; No facings.	80 psi	5 hrs.		1		1, 20	5
W-16-M-10	16"	Core: clay or shale structural tile; see Notes 4, 8, 15, 18; No facings.	80 psi	9 hrs.		1		1, 20	9
W-16-M-11	16"	Core: clay or shale structural tile; see Notes 3, 7, 14, 18; No facings.	80 psi	6 hrs.		1		1, 20	6

(Continued)

**TABLE 1.1.7—MASONRY WALLS
14" OR MORE THICK—continued**

ITEM CODE	THICKNESS	CONSTRUCTION DETAILS	PERFORMANCE		REFERENCE NUMBER			NOTES	REC. HOURS
			LOAD	TIME	PRE-BMS-92	BMS-92	POST-BMS-92		
W-16-M-12	16"	Core: clay or shale structural tile; see Notes 4, 8, 16, 18; No facings.	80 psi	10 hrs.		1		1, 20	10
W-16-M-13	16"	Core: clay or shale structural tile; see Notes 4, 6, 16, 19; No facings.	80 psi	7 hrs.		1		1, 20	7
W-16-M-14	16 ⁵ / ₈ "	Core: clay or shale structural tile; see Notes 4, 7, 9, 18; Facings: side 1, see Note 17; side 2, none.	80 psi	6 hrs.		1		1, 20	6
W-16-M-15	16 ⁵ / ₈ "	Core: clay or shale structural tile; see Notes 4, 7, 9, 19; Facings: fire side only; see Note 17.	80 psi	5 hrs.		1		1, 20	5
W-16-M-16	16 ⁵ / ₈ "	Core: clay or shale structural tile; see Notes 4, 7, 10, 18; Facings: side 1, see Note 17; side 2, none.	80 psi	7 hrs.		1		1, 20	7
W-16-M-17	16 ⁵ / ₈ "	Core: clay or shale structural tile; see Notes 4, 7, 10, 19; Facings: fire side only; see Note 17.	80 psi	5 hrs.		1		1, 20	5
W-16-M-18	16 ⁵ / ₈ "	Core: clay or shale structural tile; see Notes 4, 7, 11, 18; Facings: side 1, see Note 17; side 2, none.	80 psi	5 hrs.		1		1, 20	8
W-16-M-19	16 ⁵ / ₈ "	Core: clay or shale structural tile; see Notes 4, 7, 11, 19; Facings: fire side only; see Note 17.	80 psi	6 hrs.		1		1, 20	6
W-16-M-20	16 ⁵ / ₈ "	Core: clay or shale structural tile; see Notes 4, 8, 13, 18; Facings: sides 1 and 2; see Note 17.	80 psi	11 hrs.		1		1, 20	11
W-16-M-21	16 ⁵ / ₈ "	Core: clay or shale structural tile; see Notes 4, 8, 13 18; Facings: side 1, see Note 17; side 2, none.	80 psi	9 hrs.		1		1, 20	9
W-16-M-22	16 ⁵ / ₈ "	Core: clay or shale structural tile; see Notes 4, 8, 13, 19; Facings: fire side only; see Note 17.	80 psi	6 hrs.		1		1, 20	6
W-16-M-23	16 ⁵ / ₈ "	Core: clay or shale structural tile; see Notes 4, 8, 15, 18; Facings: side 1, see Note 17; side 2, none.	80 psi	10 hrs.		1		1, 20	10
W-16-M-24	16 ⁵ / ₈ "	Core: clay or shale structural tile; see Notes 4, 8, 15, 19; Facings: fire side only; see Note 17.	80 psi	7 hrs.		1		1, 20	7
W-16-M-25	16 ⁵ / ₈ "	Core: clay or shale structural tile; see Notes 4, 6, 16, 18; Facings: side 1, see Note 17; side 2, none.	80 psi	11 hrs.		1		1, 20	11
W-16-M-26	16 ⁵ / ₈ "	Core: clay or shale structural tile; see Notes 4, 6, 16, 19; Facings: fire side only; see Note 17.	80 psi	8 hrs.		1		1, 20	8
W-17-M-27	17 ¹ / ₄ "	Core: clay or shale structural tile; see Notes 4, 7, 9, 18; Facings: sides 1 and 2; see Note 17.	80 psi	8 hrs.		1		1, 20	8
W-17-M-28	17 ¹ / ₄ "	Core: clay or shale structural tile; see Notes 4, 7, 10, 18; Facings: sides 1 and 2; see Note 17.	80 psi	9 hrs.		1		1, 20	9

(Continued)

**TABLE 1.1.7—MASONRY WALLS
14" OR MORE THICK—continued**

ITEM CODE	THICKNESS	CONSTRUCTION DETAILS	PERFORMANCE		REFERENCE NUMBER			NOTES	REC. HOURS
			LOAD	TIME	PRE-BMS-92	BMS-92	POST-BMS-92		
W-17-M-29	17 ¹ / ₄ "	Core: clay or shale structural tile; see Notes 4, 7, 11, 18; Facings: sides 1 and 2; see Note 17.	80 psi	10 hrs.		1		1, 20	10
W-17-M-30	17 ¹ / ₄ "	Core: clay or shale structural tile; see Notes 4, 8, 15, 18; Facings: sides 1 and 2; see Note 17.	80 psi	12 hrs.		1		1, 20	12
W-17-M-31	17 ¹ / ₄ "	Core: clay or shale structural tile; see Notes 4, 6, 16, 18; Facings: sides 1 and 2; see Note 17.	80 psi	13 hrs.		1		1, 20	13

For SI: 1 inch = 25.4 mm, 1 pound per square inch = 0.00689 MPa.

Notes:

1. Tested at NBS - ASA Spec. No. A2-1934.
2. One unit in wall thickness.
3. Two units in wall thickness.
4. Two or three units in wall thickness.
5. Two cells in wall thickness.
6. Three or four cells in wall thickness.
7. Four or five cells in wall thickness.
8. Five or six cells in wall thickness.
9. Minimum percent of solid materials in units = 40%.
10. Minimum percent of solid materials in units = 43%.
11. Minimum percent of solid materials in units = 46%.
12. Minimum percent of solid materials in units = 48%.
13. Minimum percent of solid materials in units = 49%.
14. Minimum percent of solid materials in units = 45%.
15. Minimum percent of solid materials in units = 51%.
16. Minimum percent of solid materials in units = 53%.
17. Not less than ⁵/₈ inch thickness of 1:3 sanded gypsum plaster.
18. Noncombustible or no members framed into wall.
19. Combustible members framed into wall.
20. Load: 80 psi for gross area.
21. Portland cement-lime mortar.
22. Failure mode - thermal.
23. British test.
24. Passed all criteria.
25. Failed by sudden collapse with no preceding signs of impending failure.
26. One cell in wall thickness.
27. Two cells in wall thickness.
28. Three cells in wall thickness.
29. Minimum percent of solid material in concrete units = 52%.
30. Minimum percent of solid material in concrete units = 54%.
31. Minimum percent of solid material in concrete units = 55%.
32. Minimum percent of solid material in concrete units = 57%.
33. Minimum percent of solid material in concrete units = 60%.
34. Minimum percent of solid material in concrete units = 62%.
35. Minimum percent of solid material in concrete units = 65%.
36. Minimum percent of solid material in concrete units = 70%.
37. Minimum percent of solid material in concrete units = 76%.
38. Not less than ¹/₂ inch of 1:3 sanded gypsum plaster.
39. Three units in wall thickness.
40. Concrete units made with expanded slag or pumice aggregates.
41. Concrete units made with expanded burned clay or shale, crushed limestone, air cooled slag or cinders.
42. Concrete units made with calcareous sand and gravel. Coarse aggregate, 60 percent or more calcite and dolomite.
43. Concrete units made with siliceous sand and gravel. Ninety percent or more quartz, chert or flint.

**FIGURE 1.2.1—METAL FRAME WALLS
0" TO LESS THAN 4" THICK**

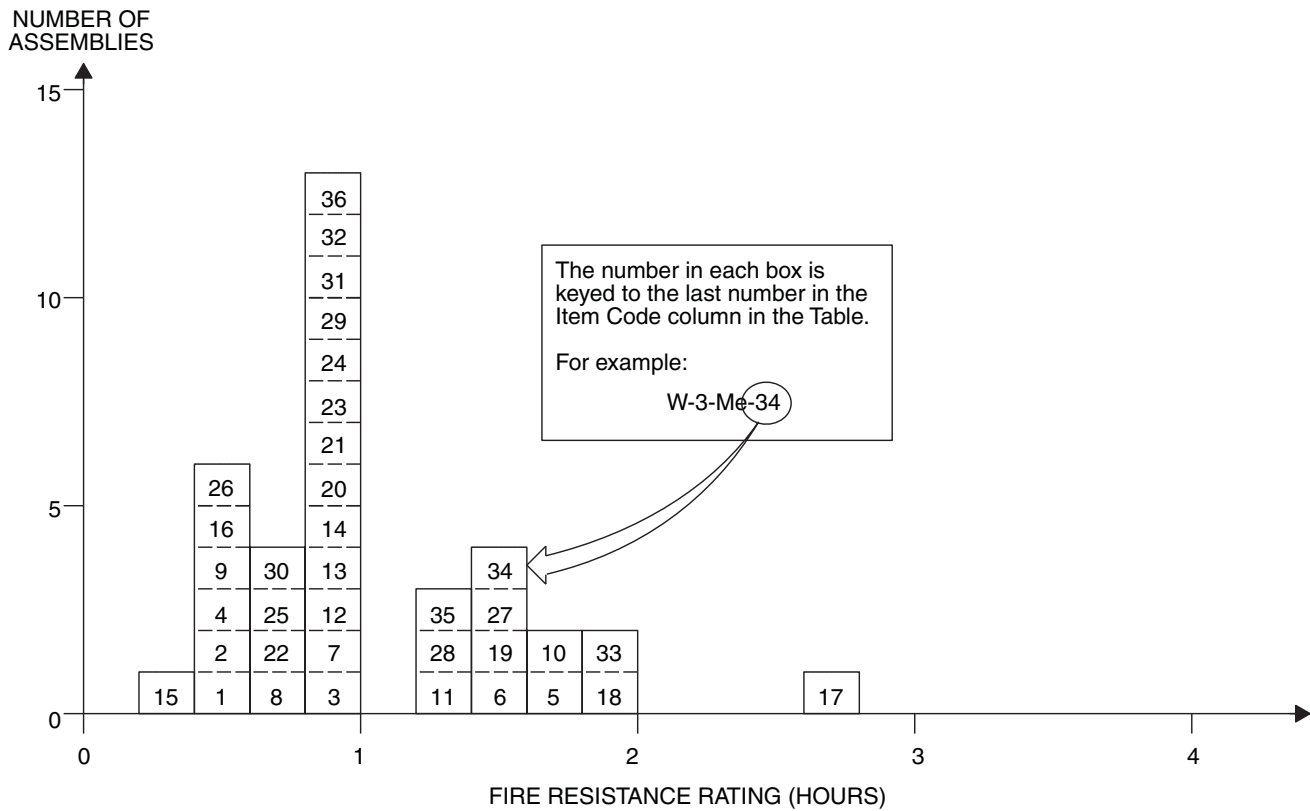

**TABLE 1.2.1—METAL FRAME WALLS
0" TO LESS THAN 4" THICK**

ITEM CODE	THICKNESS	CONSTRUCTION DETAILS	PERFORMANCE		REFERENCE NUMBER			NOTES	REC. HOURS
			LOAD	TIME	PRE-BMS-92	BMS-92	POST-BMS-92		
W-3-Me-1	3"	Core: steel channels having three rows of 4" x 1/8" staggered slots in web; core filled with heat expanded vermiculite weighing 1.5 lbs./ft. ² of wall area; Facings: sides 1 and 2, 18 gage steel, spot welded to core.	N/A	25 min.		1			1/3
W-3-Me-2	3"	Core: steel channels having three rows of 4" x 1/8" staggered slots in web; core filled with heat expanded vermiculite weighing 2 lbs./ft. ² of wall area; Facings: sides 1 and 2, 18 gage steel, spot welded to core.	N/A	30 min.		1			1/2
W-3-Me-3	2 1/2"	Solid partition: 3/8" tension rods (vertical) 3' o.c. with metal lath; Scratch coat: cement/sand/lime plaster; Float coats: cement/sand/lime plaster; Finish coats: neat gypsum plaster.	N/A	1 hr.			7	1	1
W-2-Me-4	2"	Solid wall: steel channel per Note 1; 2" thickness of 1:2; 1:3 portland cement on metal lath.	N/A	30 min.		1			1/2

(Continued)

**TABLE 1.2.1—METAL FRAME WALLS
0" TO LESS THAN 4" THICK—continued**

ITEM CODE	THICKNESS	CONSTRUCTION DETAILS	PERFORMANCE		REFERENCE NUMBER			NOTES	REC. HOURS
			LOAD	TIME	PRE-BMS-92	BMS-92	POST-BMS-92		
W-2-Me-5	2"	Solid wall: steel channel per Note 1; 2" thickness of neat gypsum plaster on metal lath.	N/A	1 hr. 45 min.		1			1 ³ / ₄
W-2-Me-6	2"	Solid wall: steel channel per Note 1; 2" thickness of 1:1 ¹ / ₂ ; 1:1 ¹ / ₂ gypsum plaster on metal lath.	N/A	1 hr. 30 min.		1			1 ¹ / ₂
W-2-Me-7	2"	Solid wall: steel channel per Note 2; 2" thickness of 1:1; 1:1 gypsum plaster on metal lath.	N/A	1 hr.		1			1
W-2-Me-8	2"	Solid wall: steel channel per Note 1; 2" thickness of 1:2; 1:2 gypsum plaster on metal lath.	N/A	45 min.		1			³ / ₄
W-2-Me-9	2 ¹ / ₄ "	Solid wall: steel channel per Note 2; 2 ¹ / ₄ " thickness of 1:2; 1:3 portland cement on metal lath.	N/A	30 min.		1			¹ / ₂
W-2-Me-10	2 ¹ / ₄ "	Solid wall: steel channel per Note 2; 2 ¹ / ₄ " thickness of neat gypsum plaster on metal lath.	N/A	2 hrs.		1			2
W-2-Me-11	2 ¹ / ₄ "	Solid wall: steel channel per Note 2; 2 ¹ / ₄ " thickness of 1:1 ¹ / ₂ ; 1:1 ¹ / ₂ gypsum plaster on metal lath.	N/A	1 hr. 45 min.		1			1 ³ / ₄
W-2-Me-12	2 ¹ / ₄ "	Solid wall: steel channel per Note 2; 2 ¹ / ₄ " thickness of 1:1; 1:1 gypsum plaster on metal lath.	N/A	1 hr. 15 min.		1			1 ¹ / ₄
W-2-Me-13	2 ¹ / ₄ "	Solid wall: steel channel per Note 2; 2 ¹ / ₄ " thickness of 1:2; 1:2 gypsum plaster on metal lath.	N/A	1 hr.		1			1
W-2-Me-14	2 ¹ / ₂ "	Solid wall: steel channel per Note 1; 2 ¹ / ₂ " thickness of 4.5:1:7; 4.5:1:7 portland cement, sawdust and sand sprayed on wire mesh; see Note 3.	N/A	1 hr.		1			1
W-2-Me-15	2 ¹ / ₂ "	Solid wall: steel channel per Note 2; 2 ¹ / ₂ " thickness of 1:4; 1:4 portland cement sprayed on wire mesh; see Note 3.	N/A	20 min.		1			¹ / ₃
W-2-Me-16	2 ¹ / ₂ "	Solid wall: steel channel per Note 2; 2 ¹ / ₂ " thickness of 1:2; 1:3 portland cement on metal lath.	N/A	30 min.		1			¹ / ₂
W-2-Me-17	2 ¹ / ₂ "	Solid wall: steel channel per Note 2; 2 ¹ / ₂ " thickness of neat gypsum plaster on metal lath.	N/A	2 hrs. 30 min.		1			2 ¹ / ₂
W-2-Me-18	2 ¹ / ₂ "	Solid wall: steel channel per Note 2; 2 ¹ / ₂ " thickness of 1:1 ¹ / ₂ ; 1:1 ¹ / ₂ gypsum plaster on metal lath.	N/A	2 hrs.		1			2
W-2-Me-19	2 ¹ / ₂ "	Solid wall: steel channel per Note 2; 2 ¹ / ₂ " thickness of 1:1; 1:1 gypsum plaster on metal lath.	N/A	1 hr. 30 min.		1			1 ¹ / ₂
W-2-Me-20	2 ¹ / ₂ "	Solid wall: steel channel per Note 2; 2 ¹ / ₂ " thickness of 1:2; 1:2 gypsum plaster on metal lath.	N/A	1 hr.		1			1

(Continued)

**TABLE 1.2.1—METAL FRAME WALLS
0" TO LESS THAN 4" THICK—continued**

ITEM CODE	THICKNESS	CONSTRUCTION DETAILS	PERFORMANCE		REFERENCE NUMBER			NOTES	REC. HOURS
			LOAD	TIME	PRE-BMS-92	BMS-92	POST-BMS-92		
W-2-Me-21	2 1/2"	Solid wall: steel channel per Note 2; 2 1/2" thickness of 1:2; 1:3 gypsum plaster on metal lath.	N/A	1 hr.		1			1
W-3-Me-22	3"	Core: steel channel per Note 2; 1:2; 1:2 gypsum plaster on 3/4" soft asbestos lath; plaster thickness 2".	N/A	45 min.		1			3/4
W-3-Me-23	3 1/2"	Solid wall: steel channel per Note 2; 2 1/2" thickness of 1:2; 1:2 gypsum plaster on 3/4" asbestos lath.	N/A	1 hr.		1			1
W-3-Me-24	3 1/2"	Solid wall: steel channel per Note 2; lath over and 1:2 1/2; 1:2 1/2 gypsum plaster on 1" magnesium oxysulfate wood fiberboard; plaster thickness 2 1/2".	N/A	1 hr.		1			1
W-3-Me-25	3 1/2"	Core: steel studs; see Note 4; Facings: 3/4" thickness of 1:1/30; 2; 1:1/30; 3 portland cement and asbestos fiber plaster.	N/A	45 min.		1			3/4
W-3-Me-26	3 1/2"	Core: steel studs; see Note 4; Facings: both sides 3/4" thickness of 1:2; 1:3 portland cement.	N/A	30 min.		1			1/2
W-3-Me-27	3 1/2"	Core: steel studs; see Note 4; Facings: both sides 3/4" thickness of neat gypsum plaster.	N/A	1 hr. 30 min.		1			1 1/2
W-3-Me-28	3 1/2"	Core: steel studs; see Note 4; Facings: both sides 3/4" thickness of 1:1/2; 1:1/2 gypsum plaster.	N/A	1 hr. 15 min.		1			1 1/4
W-3-Me-29	3 1/2"	Core: steel studs; see Note 4; Facings: both sides 3/4" thickness of 1:2; 1:2 gypsum plaster.	N/A	1 hr.		1			1
W-3-Me-30	3 1/2"	Core: steel studs; see Note 4; Facings: both sides 3/4" thickness of 1:2; 1:3 gypsum plaster.	N/A	45 min.		1			3/4
W-3-Me-31	3 3/4"	Core: steel studs; see Note 4; Facings: both sides 7/8" thickness of 1:1/30; 2; 1:1/30; 3 portland cement and asbestos fiber plaster.	N/A	1 hr.		1			1
W-3-Me-32	3 3/4"	Core: steel studs; see Note 4; Facings: both sides 7/8" thickness of 1:2; 1:3 portland cement.	N/A	45 min.		1			3/4
W-3-Me-33	3 3/4"	Core: steel studs; see Note 4; Facings: both sides 7/8" thickness of neat gypsum plaster.	N/A	2 hrs.		1			2
W-3-Me-34	3 3/4"	Core: steel studs; see Note 4; Facings: both sides 7/8" thickness of 1:1/2; 1:1/2 gypsum plaster.	N/A	1 hr. 30 min.		1			1 1/2
W-3-Me-35	3 3/4"	Core: steel studs; see Note 4; Facings: both sides 7/8" thickness of 1:2; 1:2 gypsum plaster.	N/A	1 hr. 15 min.		1			1 1/4

(Continued)

**TABLE 1.2.1—METAL FRAME WALLS
0" TO LESS THAN 4" THICK—continued**

ITEM CODE	THICKNESS	CONSTRUCTION DETAILS	PERFORMANCE		REFERENCE NUMBER			NOTES	REC. HOURS
			LOAD	TIME	PRE-BMS-92	BMS-92	POST-BMS-92		
W-3-Me-36	3 ³ / ₄ "	Core: steel; see Note 4; Facings: 7/8" thickness of 1:2; 1:3 gypsum plaster on both sides.	N/A	1 hr.		1			1

For SI: 1 inch = 25.4 mm.

Notes:

1. Failure mode - local temperature rise - back face.
2. Three-fourths inch or 1 inch channel framing - hot-rolled or strip-steel channels.
3. Reinforcement is 4-inch square mesh of No. 6 wire welded at intersections (no channels).
4. Ratings are for any usual type of nonload-bearing metal framing providing 2 inches (or more) air space.

General Note:

The construction details of the wall assemblies are as complete as the source documentation will permit. Data on the method of attachment of facings and the gauge of steel studs was provided when known. The cross-sectional area of the steel stud can be computed, thereby permitting a reasoned estimate of actual loading conditions. For load-bearing assemblies, the maximum allowable stress for the steel studs has been provided in the table "Notes." More often, it is the thermal properties of the facing materials, rather than the specific gauge of the steel, that will determine the degree of fire resistance. This is particularly true for nonbearing wall assemblies.

**FIGURE 1.2.2—METAL FRAME WALLS
4" TO LESS THAN 6" THICK**

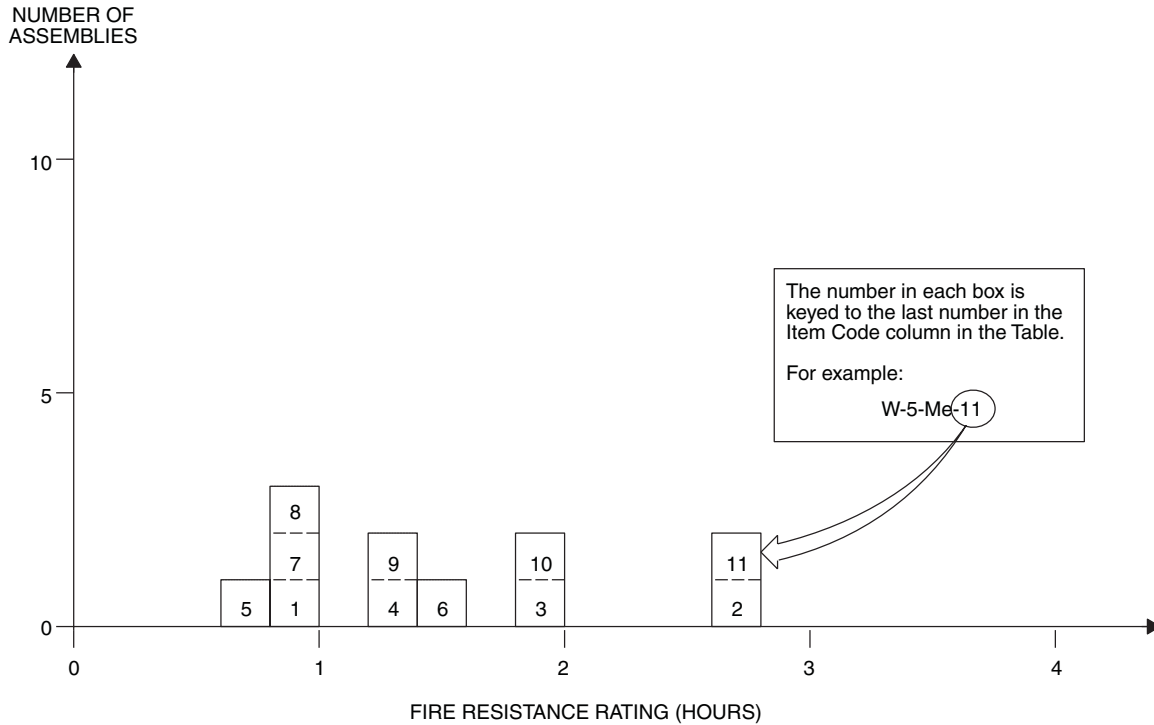

**TABLE 1.2.2—METAL FRAME WALLS
4" TO LESS THAN 6" THICK**

ITEM CODE	THICKNESS	CONSTRUCTION DETAILS	PERFORMANCE		REFERENCE NUMBER			NOTES	REC. HOURS
			LOAD	TIME	PRE-BMS-92	BMS-92	POST-BMS-92		
W-5-Me-1	5 1/2"	3" cavity with 16 ga. channel studs (3 1/2" o.c.) of 1/2" x 1/2" channel and 3" spacer; Metal lath on ribs with plaster (three coats) 3/4" over face of lath; Plaster (each side): scratch coat, cement/lime/sand with hair; float coat, cement/lime/sand; finish coat, neat gypsum.	N/A	1 hr. 11 min.			7	1	1
W-4-Me-2	4"	Core: steel studs; see Note 2; Facings: both sides 1" thickness of neat gypsum plaster.	N/A	2 hrs. 30 min.		1			2 1/2
W-4-Me-3	4"	Core: steel studs; see Note 2; Facings: both sides 1" thickness of 1:1/2; 1:1/2 gypsum plaster.	N/A	2 hrs.		1			2
W-4-Me-4	4"	Core: steel; see Note 2; Facings: both sides 1" thickness of 1:2; 1:3 gypsum plaster.	N/A	1 hr. 15 min.		1			1 1/4
W-4-Me-5	4 1/2"	Core: lightweight steel studs 3" in depth; Facings: both sides 3/4" thick sanded gypsum plaster, 1:2 scratch coat, 1:3 brown coat applied on metal lath.	See Note 4	45 min.		1		5	3/4
W-4-Me-6	4 1/2"	Core: lightweight steel studs 3" in depth; Facings: both sides 3/4" thick neat gypsum plaster on metal lath.	See Note 4	1 hr. 30 min.		1		5	1 1/2

(Continued)

**TABLE 1.2.2—METAL FRAME WALLS
4" TO LESS THAN 6" THICK—continued**

ITEM CODE	THICKNESS	CONSTRUCTION DETAILS	PERFORMANCE		REFERENCE NUMBER			NOTES	REC. HOURS
			LOAD	TIME	PRE-BMS-92	BMS-92	POST-BMS-92		
W-4-Me-7	4 ¹ / ₂ "	Core: lightweight steel studs 3" in depth; Facings: both sides ³ / ₄ " thick sanded gypsum plaster, 1:2 scratch and brown coats applied on metal lath.	See Note 4	1 hr.		1		5	1
W-4-Me-8	4 ³ / ₄ "	Core: lightweight steel studs 3" in depth; Facings: both sides ⁷ / ₈ " thick sanded gypsum plaster, 1:2 scratch coat, 1:3 brown coat, applied on metal lath.	See Note 4	1 hr.		1		5	1
W-4-Me-9	4 ³ / ₄ "	Core: lightweight steel studs 3" in depth; Facings: both sides ⁷ / ₈ " thick sanded gypsum plaster, 1:2 scratch and 1:3 brown coats applied on metal lath.	See Note 4	1 hr. 15 min.		1		5	1 ¹ / ₄
W-5-Me-10	5"	Core: lightweight steel studs 3" in depth; Facings: both sides 1" thick neat gypsum plaster on metal lath.	See Note 4	2 hrs.		1		5	2
W-5-Me-11	5"	Core: lightweight steel studs 3" in depth; Facings: both sides 1" thick neat gypsum plaster on metal lath.	See Note 4	2 hrs. 30 min.		1		5, 6	2 ¹ / ₂

For SI: 1 inch = 25.4 mm, 1 pound per square inch = 0.00689 MPa.

Notes:

1. Failure mode - local back face temperature rise.
2. Ratings are for any usual type of non-bearing metal framing providing a minimum 2 inches air space.
3. Facing materials secured to lightweight steel studs not less than 3 inches deep.
4. Rating based on loading to develop a maximum stress of 7270 psi for net area of each stud.
5. Spacing of steel studs must be sufficient to develop adequate rigidity in the metal-lath or gypsum-plaster base.
6. As per Note 4 but load/stud not to exceed 5120 psi.

General Note:

The construction details of the wall assemblies are as complete as the source documentation will permit. Data on the method of attachment of facings and the gauge of steel studs was provided when known. The cross sectional area of the steel stud can be computed, thereby permitting a reasoned estimate of actual loading conditions. For load-bearing assemblies, the maximum allowable stress for the steel studs has been provided in the table "Notes." More often, it is the thermal properties of the facing materials, rather than the specific gauge of the steel, that will determine the degree of fire resistance. This is particularly true for nonbearing wall assemblies.

**TABLE 1.2.3—METAL FRAME WALLS
6" TO LESS THAN 8" THICK**

ITEM CODE	THICKNESS	CONSTRUCTION DETAILS	PERFORMANCE		REFERENCE NUMBER			NOTES	REC. HOURS
			LOAD	TIME	PRE-BMS-92	BMS-92	POST-BMS-92		
W-6-Me-1	6 ⁵ / ₈ "	On one side of 1" magnesium oxysulfate wood fiberboard sheathing attached to steel studs (see Notes 1 and 2), 1" air space, 3 ³ / ₄ " brick secured with metal ties to steel frame every fifth course; Inside facing of 7/ ₈ " 1:2 sanded gypsum plaster on metal lath secured directly to studs; Plaster side exposed to fire.	See Note 2	1 hr. 45 min.		1		1	1 ³ / ₄
W-6-Me-2	6 ⁵ / ₈ "	On one side of 1" magnesium oxysulfate wood fiberboard sheathing attached to steel studs (see Notes 1 and 2), 1" air space, 3 ³ / ₄ " brick secured with metal ties to steel frame every fifth course; Inside facing of 7/ ₈ " 1:2 sanded gypsum plaster on metal lath secured directly to studs; Brick face exposed to fire.	See Note 2	4 hrs.		1		1	4
W-6-Me-3	6 ⁵ / ₈ "	On one side of 1" magnesium oxysulfate wood fiberboard sheathing attached to steel studs (see Notes 1 and 2), 1" air space, 3 ³ / ₄ " brick secured with metal ties to steel frame every fifth course; Inside facing of 7/ ₈ " vermiculite plaster on metal lath secured directly to studs; Plaster side exposed to fire.	See Note 2	2 hrs.		1		1	2

For SI: 1 inch = 25.4 mm, 1 pound per square inch = 0.00689 MPa.

Notes:

1. Lightweight steel studs (minimum 3 inches deep) used. Stud spacing dependent on loading, but in each case, spacing is to be such that adequate rigidity is provided to the metal lath plaster base.
2. Load is such that stress developed in studs is not greater than 5120 psi calculated from net stud area.

General Note:

The construction details of the wall assemblies are as complete as the source documentation will permit. Data on the method of attachment of facings and the gauge of steel studs was provided when known. The cross sectional area of the steel stud can be computed, thereby permitting a reasoned estimate of actual loading conditions. For load-bearing assemblies, the maximum allowable stress for the steel studs has been provided in the table "Notes." More often, it is the thermal properties of the facing materials, rather than the specific gauge of the steel, that will determine the degree of fire resistance. This is particularly true for nonbearing wall assemblies.

**TABLE 1.2.4—METAL FRAME WALLS
8" TO LESS THAN 10" THICK**

ITEM CODE	THICKNESS	CONSTRUCTION DETAILS	PERFORMANCE		REFERENCE NUMBER			NOTES	REC. HOURS
			LOAD	TIME	PRE-BMS-92	BMS-92	POST-BMS-92		
W-9-Me-1	9 ¹ / ₁₆ "	On one side of 1/2" wood fiberboard sheathing next to studs, 3/4" air space formed with 3/4" x 1 ⁵ / ₈ " wood strips placed over the fiberboard and secured to the studs, paper backed wire lath nailed to strips 3 ³ / ₄ " brick veneer held in place by filling a 3/4" space between the brick and paper backed lath with mortar; Inside facing of 3/4" neat gypsum plaster on metal lath attached to 5/16" plywood strips secured to edges of steel studs; Rated as combustible because of the sheathing; See Notes 1 and 2; Plaster exposed.	See Note 2	1 hr. 45 min.		1		1	1 ³ / ₄
W-9-Me-2	9 ¹ / ₁₆ "	Same as above with brick exposed.	See Note 2	4 hrs.		1		1	4
W-8-Me-3	8 ¹ / ₂ "	On one side of paper backed wire lath attached to studs and 3 ³ / ₄ " brick veneer held in place by filling a 1" space between the brick and lath with mortar; Inside facing of 1" paper-enclosed mineral wool blanket weighing .6 lb./ft. ² attached to studs, metal lath or paper backed wire lath laid over the blanket and attached to the studs, 3/4" sanded gypsum plaster 1:2 for the scratch coat and 1:3 for the brown coat; See Notes 1 and 2; Plaster face exposed.	See Note 2	4 hrs.		1		1	4
W-8-Me-4	8 ¹ / ₂ "	Same as above with brick exposed.	See Note 2	5 hrs.		1		1	5

For SI: 1 inch = 25.4 mm, 1 pound per square inch = 0.00689 MPa.

Notes:

1. Lightweight steel studs ≥ 3 inches in depth. Stud spacing dependent on loading, but in any case, the spacing is to be such that adequate rigidity is provided to the metal-lath plaster base.
2. Load is such that stress developed in studs is ≤ 5120 psi calculated from the net area of the stud.

General Note:

The construction details of the wall assemblies are as complete as the source documentation will permit. Data on the method of attachment of facings and the gauge of steel studs was provided when known. The cross sectional area of the steel stud can be computed, thereby permitting a reasoned estimate of actual loading conditions. For load-bearing assemblies, the maximum allowable stress for the steel studs has been provided in the table "Notes." More often, it is the thermal properties of the facing materials, rather than the specific gauge of the steel, that will determine the degree of fire resistance. This is particularly true for nonbearing wall assemblies.

**TABLE 1.3.1—WOOD FRAME WALLS
0" TO LESS THAN 4" THICK**

ITEM CODE	THICKNESS	CONSTRUCTION DETAILS	PERFORMANCE		REFERENCE NUMBER			NOTES	REC. HOURS
			LOAD	TIME	PRE-BMS-92	BMS-92	POST-BMS-92		
W-3-W-1	3 ³ / ₄ "	Solid wall: 2 ¹ / ₄ " wood-wool slab core; ³ / ₄ " gypsum plaster each side.	N/A	2 hrs.			7	1, 6	2
W-3-W-2	3 ⁷ / ₈ "	2 × 4 stud wall; ³ / ₁₆ " thick cement asbestos board on both sides of wall.	360 psi net area	10 min.		1		2-5	1/6
W-3-W-3	3 ⁷ / ₈ "	Same as W-3-W-2 but stud cavities filled with 1 lb./ft. ² mineral wool batts.	360 psi net area	40 min.		1		2-5	2/3

For SI: 1 inch = 25.4 mm, 1 pound per square inch = 0.00689 MPa.

Notes:

1. Achieved "Grade C" fire resistance (British).
2. Nominal 2×4 wood studs of No. 1 common or better lumber set edgewise, 2'4 plates at top and bottom and blocking at mid height of wall.
3. All horizontal joints in facing material backed by 2'4 blocking in wall.
4. Load: 360 psi of net stud cross sectional area.
5. Facings secured with 6d casing nails. Nail holes predrilled and 0.02 inch to 0.03 inch smaller than nail diameter.
6. The wood-wool core is a pressed excelsior slab which possesses insulating properties similar to cellulosic insulation.

**FIGURE 1.3.2—WOOD FRAME WALLS
4" TO LESS THAN 6" THICK**

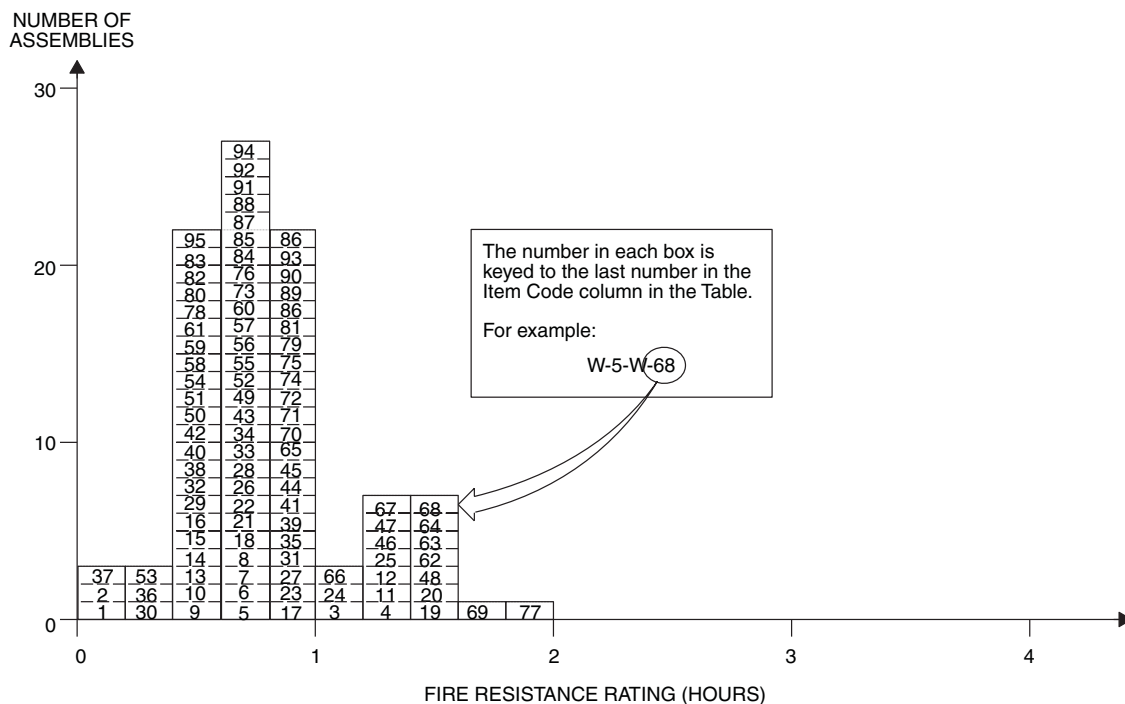

**TABLE 1.3.2—WOOD FRAME WALLS
4" TO LESS THAN 6" THICK**

ITEM CODE	THICKNESS	CONSTRUCTION DETAILS	PERFORMANCE		REFERENCE NUMBER			NOTES	REC. HOURS
			LOAD	TIME	PRE-BMS-92	BMS-92	POST-BMS-92		
W-4-W-1	4"	2" × 4" stud wall; 3/16" CAB; no insulation; Design A.	35 min.	10 min.			4	1-10	1/6
W-4-W-2	4 1/8"	2" × 4" stud wall; 3/16" CAB; no insulation; Design A.	38 min.	9 min.			4	1-10	1/6
W-4-W-3	4 3/4"	2" × 4" stud wall; 3/16" CAB and 3/8" gypsum board face (both sides); Design B.	62 min.	64 min.			4	1-10	1
W-5-W-4	5"	2" × 4" stud wall; 3/16" CAB and 1/2" gypsum board (both sides); Design B.	79 min.	Greater than 90 min.			4	1-10	1
W-4-W-5	4 3/4"	2" × 4" stud wall; 3/16" CAB and 3/8" gypsum board (both sides); Design B.	45 min.	45 min.			4	1-12	—
W-5-W-6	5"	2" × 4" stud wall; 3/16" CAB and 1/2" gypsum board face (both sides); Design B.	45 min.	45 min.			4	1-10, 12, 13	—
W-4-W-7	4"	2" × 4" stud wall; 3/16" CAB face; 3 1/2" mineral wool insulation; Design C.	40 min.	42 min.			4	1-10	2/3
W-4-W-8	4"	2" × 4" stud wall; 3/16" CAB face; 3 1/2" mineral wool insulation; Design C.	46 min.	46 min.			4	1-10, 43	2/3
W-4-W-9	4"	2" × 4" stud wall; 3/16" CAB face; 3 1/2" mineral wool insulation; Design C.	30 min.	30 min.			4	1-10, 12, 14	—

(Continued)

**TABLE 1.3.2—WOOD FRAME WALLS
4" TO LESS THAN 6" THICK—continued**

ITEM CODE	THICKNESS	CONSTRUCTION DETAILS	PERFORMANCE		REFERENCE NUMBER			NOTES	REC. HOURS
			LOAD	TIME	PRE-BMS-92	BMS-92	POST-BMS-92		
W-4-W-10	4 ¹ / ₈ "	2" × 4" stud wall; 3/16" CAB face; 3 ¹ / ₂ " mineral wool insulation; Design C.	—	30 min.			4	1-8, 12, 14	—
W-4-W-11	4 ³ / ₄ "	2" × 4" stud wall; 3/16" CAB face; 3/8" gypsum strips over studs; 5 ¹ / ₂ " mineral wool insulation; Design D.	79 min.	79 min.			4	1-10	1
W-4-W-12	4 ³ / ₄ "	2" × 4" stud wall; 3/16" CAB face; 3/8" gypsum strips at stud edges; 7 ¹ / ₂ " mineral wool insulation; Design D.	82 min.	82 min.			4	1-10	1
W-4-W-13	4 ³ / ₄ "	2" × 4" stud wall; 3/16" CAB face; 3/8" gypsum board strips over studs; 5 ¹ / ₂ " mineral wool insulation; Design D.	30 min.	30 min.			4	1-12	—
W-4-W-14	4 ³ / ₄ "	2" × 4" stud wall; 3/16" CAB face; 3/8" gypsum board strips over studs; 7" mineral wool insulation; Design D.	30 min.	30 min.			4	1-12	—
W-5-W-15	5 ¹ / ₂ "	2" × 4" stud wall; Exposed face: CAB shingles over 1" × 6"; Unexposed face: 1/8" CAB sheet; 7/16" fiberboard (wood); Design E.	34 min.	—			4	1-10	1/2
W-5-W-16	5 ¹ / ₂ "	2" × 4" stud wall; Exposed face: 1/8" CAB sheet; 7/16" fiberboard; Unexposed face: CAB shingles over 1" × 6"; Design E.	32 min.	33 min.			4	1-10	1/2
W-5-W-17	5 ¹ / ₂ "	2" × 4" stud wall; Exposed face: CAB shingles over 1" × 6"; Unexposed face: 1/8" CAB sheet; gypsum at stud edges; 3 ¹ / ₂ " mineral wool insulation; Design F.	51 min.	—			4	1-10	3/4
W-5-W-18	5 ¹ / ₂ "	2" × 4" stud wall; Exposed face: 1/8" CAB sheet; gypsum board at stud edges; Unexposed face: CAB shingles over 1" × 6"; 3 ¹ / ₂ " mineral wool insulation; Design F.	42 min.	—			4	1-10	2/3
W-5-W-19	5 ⁵ / ₈ "	2" × 4" stud wall; Exposed face: CAB shingles over 1" × 6"; Unexposed face: 1/8" CAB sheet; gypsum board at stud edges; 5 ¹ / ₂ " mineral wool insulation; Design G.	74 min.	85 min.			4	1-10	1
W-5-W-20	5 ⁵ / ₈ "	2" × 4" stud wall; Exposed face: 1/8" CAB sheet; gypsum board at 3/16" stud edges; 7/16" fiberboard; Unexposed face: CAB shingles over 1" × 6"; 5 ¹ / ₂ " mineral wool insulation; Design G.	79 min.	85 min.			4	1-10	1 ¹ / ₄
W-5-W-21	5 ⁵ / ₈ "	2" × 4" stud wall; Exposed face: CAB shingles 1" × 6" sheathing; Unexposed face: CAB sheet; gypsum board at stud edges; 5 ¹ / ₂ " mineral wool insulation; Design G.	38 min.	38 min.			4	1-10, 12, 14	—

(Continued)

**TABLE 1.3.2—WOOD FRAME WALLS
4" TO LESS THAN 6" THICK—continued**

ITEM CODE	THICKNESS	CONSTRUCTION DETAILS	PERFORMANCE		REFERENCE NUMBER			NOTES	REC. HOURS
			LOAD	TIME	PRE-BMS-92	BMS-92	POST-BMS-92		
W-5-W-22	5 ⁵ / ₈ "	2" × 4" stud wall; Exposed face: CAB sheet; gypsum board at stud edges; Unexposed face: CAB shingles 1" × 6" sheathing; 5 ¹ / ₂ " mineral wool insulation; Design G.	38 min.	38 min.			4	1-12	—
W-6-W-23	6"	2" × 4" stud wall; 16" o.c.; 1/2" gypsum board each side; 1/2" gypsum plaster each side.	N/A	60 min.			7	15	1
W-6-W-24	6"	2" × 4" stud wall; 16" o.c.; 1/2" gypsum board each side; 1/2" gypsum plaster each side.	N/A	68 min.			7	16	1
W-6-W-25	6 ⁷ / ₈ "	2" × 4" stud wall; 18" o.c.; 3/4" gypsum plank each side; 3/16" gypsum plaster each side.	N/A	80 min.			7	15	1 ¹ / ₃
W-5-W-26	5 ¹ / ₈ "	2" × 4" stud wall; 16" o.c.; 3/8" gypsum board each side; 3/16" gypsum plaster each side.	N/A	37 min.			7	15	1/2
W-5-W-27	5 ³ / ₄ "	2" × 4" stud wall; 16" o.c.; 3/8" gypsum lath each side; 1/2" gypsum plaster each side.	N/A	52 min.			7	15	3/4
W-5-W-28	5"	2" × 4" stud wall; 16" o.c.; 1/2" gypsum board each side.	N/A	37 min.			7	16	1/2
W-5-W-29	5"	2" × 4" stud wall; 1/2" fiberboard both sides 14% M.C. with F.R. paint at 35 gm./ft. ² .	N/A	28 min.			7	15	1/3
W-4-W-30	4 ³ / ₄ "	2" × 4" stud wall; Fire side: 1/2" (wood) fiberboard; Back side: 1/4" CAB; 16" o.c.	N/A	17 min.			7	15, 16	1/4
W-5-W-31	5 ¹ / ₈ "	2" × 4" stud wall; 16" o.c.; 1/2" fiberboard insulation with 1/32" asbestos (both sides of each board).	N/A	50 min.			7	16	3/4
W-4-W-32	4 ¹ / ₄ "	2" × 4" stud wall; 3/8" thick gypsum wallboard on both faces; insulated cavities.	See Note 23	25 min.		1		17, 18, 23	1/3
W-4-W-33	4 ¹ / ₂ "	2" × 4" stud wall; 1/2" thick gypsum wallboard on both faces.	See Note 17	40 min.		1		17, 23	1/3
W-4-W-34	4 ¹ / ₂ "	2" × 4" stud wall; 1/2" thick gypsum wallboard on both faces; insulated cavities.	See Note 17	45 min.		1		17, 18, 23	3/4
W-4-W-35	4 ¹ / ₂ "	2" × 4" stud wall; 1/2" thick gypsum wallboard on both faces; insulated cavities.	N/A	1 hr.		1		17, 18, 24	1
W-4-W-36	4 ¹ / ₂ "	2" × 4" stud wall; 1/2" thick, 1.1 lbs./ft. ² wood fiberboard sheathing on both faces.	See Note 23	15 min.		1		17, 23	1/4
W-4-W-37	4 ¹ / ₂ "	2" × 4" stud wall; 1/2" thick, 0.7 lb./ft. ² wood fiberboard sheathing on both faces.	See Note 23	10 min.		1		17, 23	1/6
W-4-W-38	4 ¹ / ₂ "	2" × 4" stud wall; 1/2" thick, flameproofed 1.6 lbs./ft. ² wood fiberboard sheathing on both faces.	See Note 23	30 min.		1		17, 23	1/2

(Continued)

**TABLE 1.3.2—WOOD FRAME WALLS
4" TO LESS THAN 6" THICK—continued**

ITEM CODE	THICKNESS	CONSTRUCTION DETAILS	PERFORMANCE		REFERENCE NUMBER			NOTES	REC. HOURS
			LOAD	TIME	PRE-BMS-92	BMS-92	POST-BMS-92		
W-4-W-39	4 1/2"	2" x 4" stud wall; 1/2" thick gypsum wallboard on both faces; insulated cavities.	See Note 23	1 hr.		1		17, 18, 23	1
W-4-W-40	4 1/2"	2" x 4" stud wall; 1/2" thick, 1:2; 1:3 gypsum plaster on wood lath on both faces.	See Note 23	30 min.		1		17, 21, 23	1/2
W-4-W-41	4 1/2"	2" x 4" stud wall; 1/2", 1:2; 1:3 gypsum plaster on wood lath on both faces; insulated cavities.	See Note 23	1 hr.		1		17, 18, 21, 24	1
W-4-W-42	4 1/2"	2" x 4" stud wall; 1/2", 1:5; 1:7.5 lime plaster on wood lath on both wall faces.	See Note 23	30 min.		1		17, 21, 23	1/2
W-4-W-43	4 1/2"	2" x 4" stud wall; 1/2" thick 1:5; 1:7.5 lime plaster on wood lath on both faces; insulated cavities.	See Note 23	45 min.		1		17, 18, 21, 23	3/4
W-4-W-44	4 5/8"	2" x 4" stud wall; 3/16" thick cement-asbestos over 3/8" thick gypsum board on both faces.	See Note 23	1 hr.		1		23, 25, 26, 27	1
W-4-W-45	4 5/8"	2" x 4" stud wall; studs faced with 4" wide strips of 3/8" thick gypsum board; 3/16" thick gypsum cement-asbestos board on both faces; insulated cavities.	See Note 23	1 hr.		1		23, 25, 27, 28	1
W-4-W-46	4 5/8"	Same as W-4-W-45 but nonload bearing.	N/A	1 hr. 15 min.		1		24, 28	1 1/4
W-4-W-47	4 7/8"	2" x 4" stud wall; 3/16" thick cement-asbestos board over 1/2" thick gypsum sheathing on both faces.	See Note 23	1 hr. 15 min.		1		23, 25, 26, 27	1 1/4
W-4-W-48	4 7/8"	Same as W-4-W-47 but nonload bearing.	N/A	1 hr. 30 min.		1		24, 27	1 1/2
W-5-W-49	5"	2" x 4" stud wall; Exterior face: 3/4" wood sheathing; asbestos felt 14 lbs./100 ft. ² and 5/32" cement-asbestos shingles; Interior face: 4" wide strips of 3/8" gypsum board over studs; wall faced with 3/16" thick cement-asbestos board.	See Note 23	40 min.		1		18, 23, 25, 26, 29	2/3
W-5-W-50	5"	2" x 4" stud wall; Exterior face: as per W-5-W-49; Interior face: 9/16" composite board consisting of 7/16" thick wood fiberboard faced with 1/8" thick cement-asbestos board; Exterior side exposed to fire.	See Note 23	30 min.		1		23, 25, 26, 30	1/2
W-5-W-51	5"	Same as W-5-W-50 but interior side exposed to fire.	See Note 23	30 min.		1		23, 25, 26	1/2
W-5-W-52	5"	Same as W-5-W-49 but exterior side exposed to fire.	See Note 23	45 min.		1		18, 23, 25, 26	3/4
W-5-W-53	5"	2" x 4" stud wall; 3/4" thick T&G wood boards on both sides.	See Note 23	20 min.		1		17, 23	1/3

(Continued)

**TABLE 1.3.2—WOOD FRAME WALLS
4" TO LESS THAN 6" THICK—continued**

ITEM CODE	THICKNESS	CONSTRUCTION DETAILS	PERFORMANCE		REFERENCE NUMBER			NOTES	REC. HOURS
			LOAD	TIME	PRE-BMS-92	BMS-92	POST-BMS-92		
W-5-W-54	5"	Same as W-5-W-53 but with insulated cavities.	See Note 23	35 min.		1		17, 18, 23	1/2
W-5-W-55	5"	2" x 4" stud wall; 3/4" thick T&G wood boards on both sides with 30 lbs./100 ft. ² asbestos; paper, between studs and boards.	See Note 23	45 min.		1		17, 23	3/4
W-5-W-56	5"	2" x 4" stud wall; 1/2" thick, 1:2; 1:3 gypsum plaster on metal lath on both sides of wall.	See Note 23	45 min.		1		17, 21, 34	3/4
W-5-W-57	5"	2" x 4" stud wall; 3/4" thick 2:1:8; 2:1:12 lime and Keene's cement plaster over metal lath on both sides of wall.	See Note 23	45 min.		1		17, 21, 23	1/2
W-5-W-58	5"	2" x 4" stud wall; 3/4" thick 2:1:8; 2:1:10 lime portland cement plaster over metal lath on both sides of wall.	See Note 23	30 min.		1		17, 21, 23	1/2
W-5-W-59	5"	2" x 4" stud wall; 3/4" thick 1:5; 1:7.5 lime plaster on metal lath on both sides of wall.	See Note 23	30 min.		1		17, 21, 23	1/2
W-5-W-60	5"	2" x 4" stud wall; 3/4" thick 1:1/30:2; 1:1/30:3 portland cement, asbestos fiber plaster on metal lath on both sides of wall.	See Note 23	45 min.		1		17, 21, 23	3/4
W-5-W-61	5"	2" x 4" stud wall; 3/4" thick 1:2; 1:3 portland cement plaster on metal lath on both sides of wall.	See Note 23	30 min.		1		17, 21, 23	1/2
W-5-W-62	5"	2" x 4" stud wall; 3/4" thick neat gypsum plaster on metal lath on both sides of wall.	N/A	1 hr. 30 min.		1		17, 22, 24	1 1/2
W-5-W-63	5"	2" x 4" stud wall; 3/4" thick neat gypsum plaster on metal lath on both sides of wall.	See Note 23	1 hr. 30 min.		1		17, 21, 23	1 1/2
W-5-W-64	5"	2" x 4" stud wall; 3/4" thick 1:2; 1:2 gypsum plaster on metal lath on both sides of wall; insulated cavities.	See Note 23	1 hr. 30 min.		1		17, 18, 21, 23	1 1/2
W-5-W-65	5"	2" x 4" stud wall; same as W-5-W-64 but cavities not insulated.	See Note 23	1 hr.		1		17, 21, 23	1
W-5-W-66	5"	2" x 4" stud wall; 3/4" thick 1:2; 1:3 gypsum plaster on metal lath on both sides of wall; insulated cavities.	See Note 23	1 hr. 15 min.		1		17, 18, 21, 23	1 1/4
W-5-W-67	5 1/16"	Same as W-5-W-49 except cavity insulation of 1.75 lbs./ft. ² mineral wool bats; rating applies when either wall side exposed to fire.	See Note 23	1 hr. 15 min.		1		23, 26, 25	1 1/4
W-5-W-68	5 1/4"	2" x 4" stud wall, 7/8" thick 1:2; 1:3 gypsum plaster on metal lath on both sides of wall; insulated cavities.	See Note 23	1 hr. 30 min.		1		17, 18, 21, 23	1 1/2

(Continued)

**TABLE 1.3.2—WOOD FRAME WALLS
4" TO LESS THAN 6" THICK—continued**

ITEM CODE	THICKNESS	CONSTRUCTION DETAILS	PERFORMANCE		REFERENCE NUMBER			NOTES	REC. HOURS
			LOAD	TIME	PRE-BMS-92	BMS-92	POST-BMS-92		
W-5-W-69	5 ¹ / ₄ "	2" × 4" stud wall; ⁷ / ₈ " thick neat gypsum plaster applied on metal lath on both sides of wall.	N/A	1 hr. 45 min.		1		17, 22, 24	1 ³ / ₄
W-5-W-70	5 ¹ / ₄ "	2" × 4" stud wall; ¹ / ₂ " thick neat gypsum plaster on ³ / ₈ " plain gypsum lath on both sides of wall.	See Note 23	1 hr.		1		17, 22, 23	1
W-5-W-71	5 ¹ / ₄ "	2" × 4" stud wall; ¹ / ₂ " thick of 1:2; 1:2 gypsum plaster on ³ / ₈ " thick plain gypsum lath with 1 ³ / ₄ " × 1 ³ / ₄ " metal lath pads nailed 8" o.c. vertically and 16" o.c. horizontally on both sides of wall.	See Note 23	1 hr.		1		17, 21, 23	1
W-5-W-72	5 ¹ / ₄ "	2" × 4" stud wall; ¹ / ₂ " thick of 1:2; 1:2 gypsum plaster on ³ / ₈ " perforated gypsum lath, one ³ / ₄ " diameter hole or larger per 16" square of lath surface, on both sides of wall.	See Note 23	1 hr.		1		17, 21, 23	1
W-5-W-73	5 ¹ / ₄ "	2" × 4" stud wall; ¹ / ₂ " thick of 1:2; 1:2 gypsum plaster on ³ / ₈ " gypsum lath (plain, indented or perforated) on both sides of wall.	See Note 23	45 min.		1		17, 21, 23	³ / ₄
W-5-W-74	5 ¹ / ₄ "	2" × 4" stud wall; ⁷ / ₈ " thick of 1:2; 1:3 gypsum plaster over metal lath on both sides of wall.	See Note 23	1 hr.		1		17, 21, 23	1
W-5-W-75	5 ¹ / ₄ "	2" × 4" stud wall; ⁷ / ₈ " thick of 1:1 ¹ / ₃₀ ; 2; 1:1 ¹ / ₃₀ ; 3 portland cement, asbestos plaster applied over metal lath on both sides of wall.	See Note 23	1 hr.		1		17, 21, 23	1
W-5-W-76	5 ¹ / ₄ "	2" × 4" stud wall; ⁷ / ₈ " thick of 1:2; 1:3 portland cement plaster over metal lath on both sides of wall.	See Note 23	45 min.		1		17, 21, 23	³ / ₄
W-5-W-77	5 ¹ / ₂ "	2" × 4" stud wall; 1" thick neat gypsum plaster over metal lath on both sides of wall; nonload bearing.	N/A	2 hrs.		1		17, 22, 24	2
W-5-W-78	5 ¹ / ₂ "	2" × 4" stud wall; ¹ / ₂ " thick of 1:2; 1:2 gypsum plaster on ¹ / ₂ " thick, 0.7 lb./ft. ² wood fiberboard on both sides of wall.	See Note 23	35 min.		1		17, 21, 23	¹ / ₂
W-4-W-79	4 ³ / ₄ "	2" × 4" wood stud wall; ¹ / ₂ " thick of 1:2; 1:2 gypsum plaster over wood lath on both sides of wall; mineral wool insulation.	N/A	1 hr.			43	21, 31, 35, 38	1
W-4-W-80	4 ³ / ₄ "	Same as W-4-W-79 but uninsulated.	N/A	35 min.			43	21, 31, 35	¹ / ₂
W-4-W-81	4 ³ / ₄ "	2" × 4" wood stud wall; ¹ / ₂ " thick of 3:1:8; 3:1:12 lime, Keene's cement, sand plaster over wood lath on both sides of wall; mineral wool insulation.	N/A	1 hr.			43	21, 31, 35, 40	1

(Continued)

**TABLE 1.3.2—WOOD FRAME WALLS
4" TO LESS THAN 6" THICK—continued**

ITEM CODE	THICKNESS	CONSTRUCTION DETAILS	PERFORMANCE		REFERENCE NUMBER			NOTES	REC. HOURS
			LOAD	TIME	PRE-BMS-92	BMS-92	POST-BMS-92		
W-4-W-82	4 ³ / ₄ "	2" × 4" wood stud wall; 1/2" thick of 1:6 ¹ / ₄ ; 1:6 ¹ / ₄ lime Keene's cement plaster over wood lath on both sides of wall; mineral wool insulation.	N/A	30 min.			43	21, 31, 35, 40	1/2
W-4-W-83	4 ³ / ₄ "	2" × 4" wood stud wall; 1/2" thick of 1:5; 1:7.5 lime plaster over wood lath on both sides of wall.	N/A	30 min.			43	21, 31, 35	1/2
W-5-W-84	5 ¹ / ₈ "	2" × 4" wood stud wall; 1 ¹ / ₁₆ " thick of 1:5; 1:7.5 lime plaster over wood lath on both sides of wall; mineral wool insulation.	N/A	45 min.			43	21, 31, 35, 39	1/2
W-5-W-85	5 ¹ / ₄ "	2" × 4" wood stud wall; 3/4" thick of 1:5; 1:7 lime plaster over wood lath on both sides of wall; mineral wool insulation.	N/A	40 min.			43	21, 31, 35, 40	2/3
W-5-W-86	5 ¹ / ₄ "	2" × 4" wood stud wall; 1/2" thick of 2:1:12 lime, Keene's cement and sand scratch coat; 1/2" thick 2:1:18 lime, Keene's cement and sand brown coat over wood lath on both sides of wall; mineral wool insulation.	N/A	1 hr.			43	21, 31, 35, 40	1
W-5-W-87	5 ¹ / ₄ "	2" × 4" wood stud wall; 1/2" thick of 1:2; 1:2 gypsum plaster over 3/8" plaster board on both sides of wall.	N/A	45 min.			43	21, 31	3/4
W-5-W-88	5 ¹ / ₄ "	2" × 4" wood stud wall; 1/2" thick of 1:2; 1:2 gypsum plaster over 3/8" gypsum lath on both sides of wall.	N/A	45 min.			43	21, 31	3/4
W-5-W-89	5 ¹ / ₄ "	2" × 4" wood stud wall; 1/2" thick of 1:2; 1:2 gypsum plaster over 3/8" gypsum lath on both sides of wall.	N/A	1 hr.			43	21, 31, 33	1
W-5-W-90	5 ¹ / ₄ "	2" × 4" wood stud wall; 1/2" thick neat plaster over 3/8" thick gypsum lath on both sides of wall.	N/A	1 hr.			43	21, 22, 31	1
W-5-W-91	5 ¹ / ₄ "	2" × 4" wood stud wall; 1/2" thick of 1:2; 1:2 gypsum plaster over 3/8" thick indented gypsum lath on both sides of wall.	N/A	45 min.			43	21, 31	3/4
W-5-W-92	5 ¹ / ₄ "	2" × 4" wood stud wall; 1/2" thick of 1:2; 1:2 gypsum plaster over 3/8" thick perforated gypsum lath on both sides of wall.	N/A	45 min.			43	21, 31, 34	3/4
W-5-W-93	5 ¹ / ₄ "	2" × 4" wood stud wall; 1/2" thick of 1:2; 1:2 gypsum plaster over 3/8" perforated gypsum lath on both sides of wall.	N/A	1 hr.			43	21, 31	1
W-5-W-94	5 ¹ / ₄ "	2" × 4" wood stud wall; 1/2" thick of 1:2; 1:2 gypsum plaster over 3/8" thick perforated gypsum lath on both sides of wall.	N/A	45 min.			43	21, 31, 34	3/4

(Continued)

**TABLE 1.3.2—WOOD FRAME WALLS
4" TO LESS THAN 6" THICK—continued**

ITEM CODE	THICKNESS	CONSTRUCTION DETAILS	PERFORMANCE		REFERENCE NUMBER			NOTES	REC. HOURS
			LOAD	TIME	PRE-BMS-92	BMS-92	POST-BMS-92		
W-5-W-95	5 1/2"	2" x 4" wood stud wall; 1/2" thick of 1:2; 1:2 gypsum plaster over 1/2" thick wood fiberboard plaster base on both sides of wall.	N/A	35 min.			43	21, 31, 36	1/2
W-5-W-96	5 3/4"	2" x 4" wood stud wall; 1/2" thick of 1:2; 1:2 gypsum plaster over 7/8" thick flameproofed wood fiberboard on both sides of wall.	N/A	1 hr.			43	21, 31, 37	1

For SI: 1 inch = 25.4 mm, 1 foot = 305 mm, 1 pound = 0.004448 kN, 1 pound per square inch = 0.00689 MPa, 1 pound per square foot = 47.9 N/m².

Notes:

1. All specimens 8 feet or 8 feet 8 inches by 10 feet, 4 inches, i.e. one-half of furnace size. See Note 42 for design cross section.
2. Specimens tested in tandem (two per exposure).
3. Test per ASA No. A2-1934 except where unloaded. Also, panels were of "half" size of furnace opening. Time value signifies a thermal failure time.
4. Two-inch by 4-inch studs: 16 inches on center; where 10 feet 4 inches, blocking at 2-foot 4-inch height.
5. Facing 4 feet by 8 feet, cement-asbestos board sheets, 3/16 inch thick.
6. Sheathing (diagonal): 25/22 inch by 5 1/2 inch, 1 inch by 6 inches pine.
7. Facing shingles: 24 inches by 12 inches by 3/32 inch where used.
8. Asbestos felt: asphalt sat between sheathing and shingles.
9. Load: 30,500 pounds or 360 psi/stud where load was tested.
10. Walls were tested beyond achievement of first test end point. A load-bearing time in excess of performance time indicates that although thermal criteria were exceeded, load-bearing ability continued.
11. Wall was rated for one hour combustible use in original source.
12. Hose steam test specimen. See table entry of similar design above for recommended rating.
13. Rated one and one-fourth hour load bearing. Rated one and one-half hour nonload bearing.
14. Failed hose stream.
15. Test terminated due to flame penetration.
16. Test terminated - local back face temperature rise.
17. Nominal 2-inch by 4-inch wood studs of No. 1 common or better lumber set edgewise. Two-inch by four-inch plates at top and bottom and blocking at mid height of wall.
18. Cavity insulation consists of rock wool bats 1.0 lb./ft.² of filled cavity area.
19. Cavity insulation consists of glass wool bats 0.6 lb./ft.² of filled cavity area.
20. Cavity insulation consists of blown-in rock wool 2.0 lbs./ft.² of filled cavity area
21. Mix proportions for plastered walls as follows: first ratio indicates scratch coat mix, weight of dry plaster: dry sand; second ratio indicates brown coat mix.
22. "Neat" plaster is taken to mean unsanded wood-fiber gypsum plaster.
23. Load: 360 psi of net stud cross sectional area.
24. Rated as nonload bearing.
25. Nominal 2-inch by 4-inch studs per Note 17, spaced at 16 inches on center.
26. Horizontal joints in facing material supported by 2-inch by 4-inch blocking within wall.
27. Facings secured with 6d casing nails. Nail holes predrilled and were 0.02 to 0.03 inch smaller than nail diameter.
28. Cavity insulation consists of mineral wool bats weighing 2 lbs./ft.² of filled cavity area.
29. Interior wall face exposed to fire.
30. Exterior wall faced exposed to fire.
31. Nominal 2-inch by 4-inch studs of yellow pine or Douglas-fir spaced 16 inches on center in a single row.
32. Studs as in Note 31 except double row, with studs in rows staggered.
33. Six roofing nails with metal-lath pads around heats to each 16-inch by 48-inch lath.
34. Areas of holes less than 2 3/4 percent of area of lath.
35. Wood laths were nailed with either 3d or 4d nails, one nail to each bearing, and the end joining broken every seventh course.
36. One-half-inch thick fiberboard plaster base nailed with 3d or 4d common wire nails spaced 4 to 6 inches on center
37. Seven-eighths-inch thick fiberboard plaster base nailed with 5d common wire nails spaced 4 to 6 inches on center
38. Mineral wood bats 1.05 to 1.25 lbs./ft.² with waterproofed-paper backing.
39. Blown-in mineral wool insulation, 2.2 lbs./ft.².
40. Mineral wool bats, 1.4 lbs./ft.² with waterproofed-paper backing.
41. Mineral wood bats, 0.9 lb./ft.².
42. See wall design diagram, below.

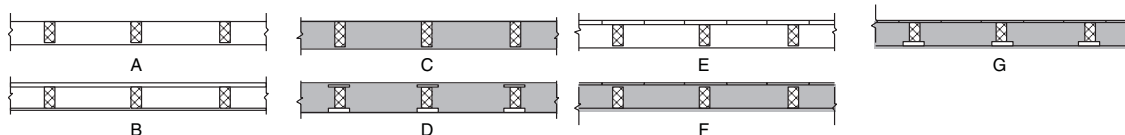

43. Duplicate specimen of W-4-W-7, tested simultaneously with W-4-W-7 in 18-foot test furnace.

**TABLE 1.3.3—WOOD FRAME WALLS
6" TO LESS THAN 8" THICK**

ITEM CODE	THICKNESS	CONSTRUCTION DETAILS	PERFORMANCE		REFERENCE NUMBER			NOTES	REC. HOURS
			LOAD	TIME	PRE-BMS-92	BMS-92	POST-BMS-92		
W-6-W-1	6 ¹ / ₄ "	2 × 4 stud wall; 1/2" thick, 1:2; 1:2 gypsum plaster on 7/8" flameproofed wood fiberboard weighing 2.8 lbs./ft. ² on both sides of wall.	See Note 3	1 hr.		1		1-3	1
W-6-W-2	6 ¹ / ₂ "	2 × 4 stud wall; 1/2" thick, 1:3; 1:3 gypsum plaster on 1" thick magnesium oxysulfate wood fiberboard on both sides of wall.	See Note 3	45 min.		1		1-3	3/4
W-7-W-3	7 ¹ / ₄ "	Double row of 2 × 4 studs, 1/2" thick of 1:2; 1:2 gypsum plaster applied over 3/8" thick perforated gypsum lath on both sides of wall; mineral wool insulation.	N/A	1 hr.			43	2, 4, 5	1
W-7-W-4	7 ¹ / ₂ "	Double row of 2 × 4 studs, 5/8" thick of 1:2; 1:2 gypsum plaster applied over 3/8" thick perforated gypsum lath over laid with 2" × 2", 16 gage wire fabric, on both sides of wall.	N/A	1 hr. 15 min.			43	2, 4	1 ¹ / ₄

For SI: 1 inch = 25.4 mm, 1 pound = 0.004448 kN, 1 pound per square inch = 0.00689 MPa, 1 pound per square foot = 47.9 N/m².

Notes:

- Nominal 2-inch by 4-inch wood studs of No. 1 common or better lumber set edgewise. Two-inch by 4-inch plates at top and bottom and blocking at mid height of wall.
- Mix proportions for plastered walls as follows: first ratio indicates scratch coat mix, weight of dry plaster:dry sand; second ratio indicates brown coat mix.
- Load: 360 psi of net stud cross sectional area.
- Nominal 2-inch by 4-inch studs of yellow pine or Douglas-fir spaced 16 inches in a double row, with studs in rows staggered.
- Mineral wool bats, 0.19 lb/ft.².

**TABLE 1.4.1—MISCELLANEOUS MATERIALS WALLS
0" TO LESS THAN 4" THICK**

ITEM CODE	THICKNESS	CONSTRUCTION DETAILS	PERFORMANCE		REFERENCE NUMBER			NOTES	REC. HOURS
			LOAD	TIME	PRE-BMS-92	BMS-92	POST-BMS-92		
W-3-Mi-1	3 ⁷ / ₈ "	Glass brick wall: (bricks 5 ³ / ₄ " × 5 ³ / ₄ " × 3 ⁷ / ₈ ") 1/4" mortar bed, cement/lime/sand; mounted in brick (9") wall with mastic and 1/2" asbestos rope.	N/A	1 hr.			7	1, 2	1
W-3-Mi-2	3"	Core: 2" magnesium oxysulfate wood-fiber blocks; laid in portland cement-lime mortar; Facings: on both sides; see Note 3.	N/A	1 hr.		1		3	1
W-3-Mi-3	3 ⁷ / ₈ "	Core: 8" × 4 ⁷ / ₈ " glass blocks 3 ⁷ / ₈ " thick weighing 4 lbs. each; laid in portland cement-lime mortar; horizontal mortar joints reinforced with metal lath.	N/A	15 min.		1			1/4

For SI: 1 inch = 25.4 mm, 1 pound = 0.004448 kN.

Notes:

- No failure reached at 1 hour.
- These glass blocks are assumed to be solid based on other test data available for similar but hollow units which show significantly reduced fire endurance.
- Minimum of 1/2 inch of 1:3 sanded gypsum plaster required to develop this rating.

**TABLE 1.4.2—MISCELLANEOUS MATERIALS WALLS
4" TO LESS THAN 6 "THICK**

ITEM CODE	THICKNESS	CONSTRUCTION DETAILS	PERFORMANCE		REFERENCE NUMBER			NOTES	REC. HOURS
			LOAD	TIME	PRE-BMS-92	BMS-92	POST-BMS-92		
W-4-Mi-1	4"	Core: 3" magnesium oxysulfate wood-fiber blocks; laid in portland cement mortar; Facings: both sides; see Note 1.	N/A	2 hrs.		1			2

For SI: 1 inch = 25.4 mm.

Notes:

1. One-half inch sanded gypsum plaster. Voids in hollow blocks to be not more than 30 percent.

FIGURE 1.5.1—FINISH RATINGS—INORGANIC MATERIALS

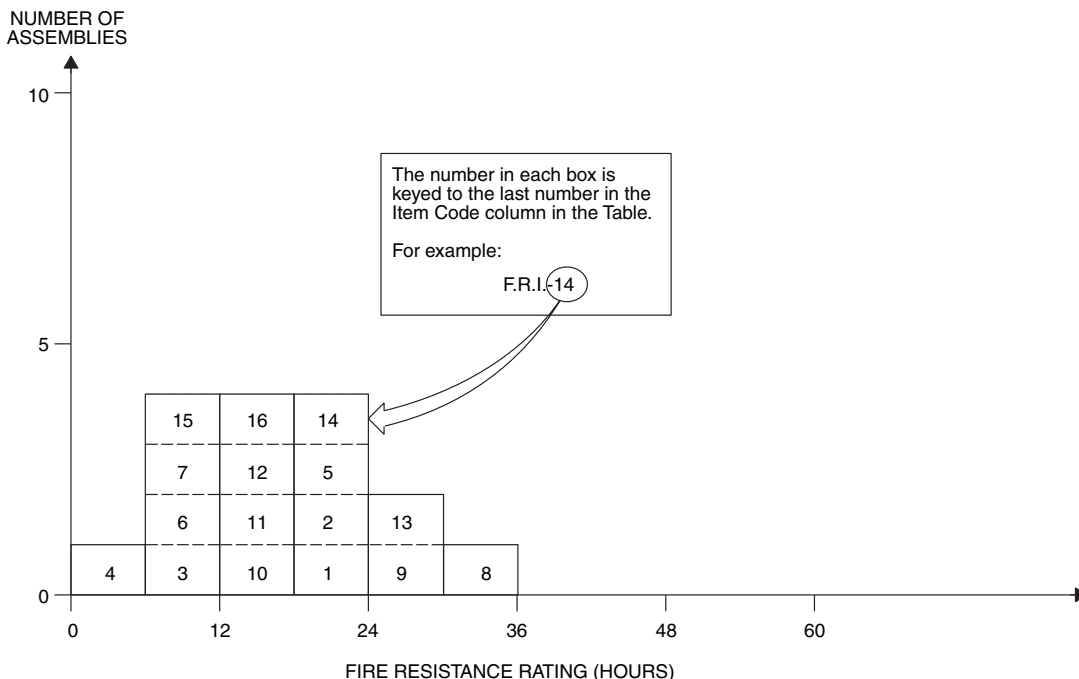

TABLE 1.5.1—FINISH RATINGS—INORGANIC MATERIALS

ITEM CODE	THICKNESS	CONSTRUCTION DETAILS	PERFORMANCE	REFERENCE NUMBER			NOTES	REC. F.R. (MIN.)
			FINISH RATING	PRE-BMS-92	BMS-92	POST-BMS-92		
F.R.-I-1	9/16"	3/8" gypsum wallboard faced with 3/16" cement-asbestos board.	20 minutes		1		1, 2	15
F.R.-I-2	11/16"	1/2" gypsum sheathing faced with 3/16" cement-asbestos board.	20 minutes		1		1, 2	20
F.R.-I-3	3/16"	3/16" cement-asbestos board over uninsulated cavity.	10 minutes		1		1, 2	5
F.R.-I-4	3/16"	3/16" cement-asbestos board over insulated cavities.	5 minutes		1		1, 2	5
F.R.-I-5	3/4"	3/4" thick 1:2; 1:3 gypsum plaster over paper backed metal lath.	20 minutes		1		1, 2, 3	20
F.R.-I-6	3/4"	3/4" thick portland cement plaster on metal lath.	10 minutes		1		1, 2	10
F.R.-I-7	3/4"	3/4" thick 1:5; 1:7.5 lime plaster on metal lath.	10 minutes		1		1, 2	10
F.R.-I-8	1"	1" thick neat gypsum plaster on metal lath.	35 minutes		1		1, 2, 4	35
F.R.-I-9	3/4"	3/4" thick neat gypsum plaster on metal lath.	30 minutes		1		1, 2, 4	30
F.R.-I-10	3/4"	3/4" thick 1:2; 1:2 gypsum plaster on metal lath.	15 minutes		1		1, 2, 3	15
F.R.-I-11	1/2"	Same as F.R.-1-7, except 1/2" thick on wood lath.	15 minutes		1		1, 2, 3	15
F.R.-I-12	1/2"	1/2" thick 1:2; 1:3 gypsum plaster on wood lath.	15 minutes		1		1, 2, 3	15

(Continued)

RESOURCE A

TABLE 1.5.1—FINISH RATINGS—INORGANIC MATERIALS—continued

ITEM CODE	THICKNESS	CONSTRUCTION DETAILS	PERFORMANCE	REFERENCE NUMBER			NOTES	REC. F.R. (MIN.)
			FINISH RATING	PRE-BMS-92	BMS-92	POST-BMS-92		
F.R.-I-13	7/8"	1/2" thick 1:2; 1:2 gypsum plaster on 3/8" perforated gypsum lath.	30 minutes		1		1, 2, 3	30
F.R.-I-14	7/8"	1/2" thick 1:2; 1:2 gypsum plaster on 3/8" thick plain or indented gypsum plaster.	20 minutes		1		1, 2, 3	20
F.R.-I-15	3/8"	3/8" gypsum wallboard.	10 minutes		1		1, 2	10
F.R.-I-16	1/2"	1/2" gypsum wallboard.	5 minutes		1		1, 2	15

For SI: 1 inch = 25.4 mm, °C = [(°F) - 32]/1.8.

Notes:

1. The finish rating is the time required to obtain an average temperature rise of 250°F, or a single point rise of 325°F, at the interface between the material being rated and the substrate being protected.
2. Tested in accordance with the Standard Specifications for Fire Tests of Building Construction and Materials, ASA No. A2-1932.
3. Mix proportions for plasters as follows: first ratio, dry weight of plaster: dry weight of sand for scratch coat; second ratio, plaster: sand for brown coat.
4. Neat plaster means unsanded wood-fiber gypsum plaster.

General Note:

The finish rating of modern building materials can be found in the current literature.

TABLE 1.5.2—FINISH RATINGS—ORGANIC MATERIALS

ITEM CODE	THICKNESS	CONSTRUCTION DETAILS	PERFORMANCE	REFERENCE NUMBER			NOTES	REC. F.R. (MIN.)
			FINISH RATING	PRE-BMS-92	BMS-92	POST-BMS-92		
F.R.-O-1	9/16"	7/16" wood fiberboard faced with 1/8" cement-asbestos board.	15 minutes		1		1, 2	15
F.R.-O-2	29/32"	3/4" wood sheathing, asbestos felt weighing 14 lbs./100 ft. ² and 3/32" cement-asbestos shingles.	20 minutes		1		1, 2	20
F.R.-O-3	1 1/2"	1" thick magnesium oxysulfate wood fiberboard faced with 1:3; 1:3 gypsum plaster, 1/2" thick.	20 minutes		1		1, 2, 3	20
F.R.-O-4	1/2"	1/2" thick wood fiberboard.	5 minutes		1		1, 2	5
F.R.-O-5	1/2"	1/2" thick flameproofed wood fiberboard.	10 minutes		1		1, 2	10
F.R.-O-6	1"	1/2" thick wood fiberboard faced with 1/2" thick 1:2; 1:2 gypsum plaster.	15 minutes		1		1, 2, 3	30
F.R.-O-7	1 3/8"	7/8" thick flameproofed wood fiberboard faced with 1/2" thick 1:2; 1:2 gypsum plaster.	30 minutes		1		1, 2, 3	30
F.R.-O-8	1 1/4"	1 1/4" thick plywood.	30 minutes			35		30

For SI: 1 inch = 25.4 mm, 1 pound = 0.004448 kN, 1 pound per square foot = 47.9 N/m², °C = [(°F) - 32]/1.8.

Notes:

1. The finish rating is the time required to obtain an average temperature rise of 250°F, or a single point rise of 325°F, at the interface between the material being rated and the substrate being protected.
2. Tested in accordance with the Standard Specifications for Fire Tests of Building Construction and Materials, ASA No. A2-1932.
3. Plaster ratios as follows: first ratio is for scratch coat, weight of dry plaster: weight of dry sand; second ratio is for the brown coat.

General Note:

The finish rating of thinner materials, particularly thinner woods, have not been listed because the possible effects of shrinkage, warpage and aging cannot be predicted.